

VEHICLE / HEAVY EQUIPMENT SAFETY INSPECTION CHECKLIST

1. INCIDENT NAME / NUMBER		2. ORDER / REQUEST NUMBER	
3. OWNER / VENDOR			
4. AGREEMENT, PO, CONTRACT NO.		5. EXPIRES	
6. MAKE	7. MODEL, TYPE		
8. SERIAL NO. / VIN		9. LICENSE NO.	

Section I - Tractor, Motor Grader	Pre-use		Release	
	Yes	No	Yes	No
1. ROPS, roll-over protection system: Manufacturer approved system secured to mainframe of tractor. Must include approved seat belts. *				
2. Lights* mounted and working while operating				
3. Battery: check for corrosion, loose terminal, hold downs				
4. Engine running: check oil pressure, knocks and leaks				
5. Gauges: all must be working; oil, temperature, etc. *				
6. Steering clutches: must have 3-4" free travel *				
7. Brakes: must hold at half travel. *				
8. Muffler and spark arrester: approved type unless turboed *				
9. Fuel system: must be free of drips and leaks *				
10. Cooling system: must be free of leaks *				
11. Fan and fan belts: check for defects				
12. Engine supports, equalizer bar, springs, main springs: check shackle bolts, shifted spring leaf *				
13. Hydraulic system: no leaks or drips				
14. Belly plate, rock and radiator guards: securely mounted *				
15. Final drive, transmission and differential: check for dripping				
16. Sprocket and idlers: cracks in spokes, sprocket teeth sharp				
17. Tracks and rollers: grouser height under 1-1/4", loose rollers, broken flanges *				
18. Blade, ripper, winch: operate smoothly and hold at any point				
19. Dozer and assembly: trunnion bolts missing, cracks *				
20. Drawbar: serviceable, safe				
21. Body and cab condition: report dents and damage				

Section II - Remarks (Describe all unsatisfactory items and identify by line number.)

Section III - Power Saw, Pump	Pre-use		Release	
	Yes	No	Yes	No
1. Visible parts broken *				
2. Visible nuts and bolts tight				
3. Oil in gear case and chain oiler				
4. Cutting bar: straight, chain in good condition *				
5. Exhaust system and spark arrester *				
6. Motor: idles evenly, runs smoothly, satisfactory power				

* Safety Item - Do not accept until brought into compliance.

10. PRE-USE INSPECTION

REJECTED

MILES / HRS _____ DATE _____ TIME _____

Inspector Name _____ Title _____
Print

ACCEPTED

MILES / HRS _____ DATE _____ TIME _____

Vendor Signature _____ Title _____

Inspector Name _____ Title _____
Print

Section IV - Truck, Bus, Van, Pickup	Pre-use		Release	
	Yes	No	Yes	No
1. DOT inspection in the last 12 months: when required *			NA	NA
2. Gauges and lights *				
3. Seat belts *				
4. Glass and mirrors *				
5. Wipers and horn *				
6. Clutch pedal: proper adjustment				
7. Cooling system: check radiator and hoses				
8. Oil level and condition: full and clean				
9. Battery: check for corrosion, loose terminals, hold downs				
10. Fuel system *				
11. Electrical system: generator and starter working				
12. Engine running: check for knocks and leaks				
13. Transmission: check for leaks				
14. Steering *				
15. Brakes *				
16. 4-Wheel drive: check gear boxes, leaks				
17. Drive line U-joints: check for looseness				
18. Springs and shocks *				
19. Differential: check for leaks				
20. Exhaust system *				
21. Frame *				
22. Tire and wheels (List failed position/depth in remarks) *				
23. Body and interior condition: describe and locate damage on back of page 3, Section IV, item 23				
24. Emergency equipment required Fire Extinguisher ___ Spare Fuses ___ Reflectors *				
25. Operator(s) properly licensed. *				

State _____ License No. _____ Class _____
 Endorsements _____ Med. Cert. Expire Date _____

11. RELEASE INSPECTION

NO DAMAGE / NO CLAIM
Not applicable to buses, inspection required

MILES / HRS _____ DATE _____ TIME _____

Vendor Signature _____ Title _____

Inspector Name _____ Title _____
Print



Section IV - Truck, Bus, Van, Pick-up

Motor vehicle parts and accessories must be in Safe Operating Condition At All Times, **FEDERAL MOTOR CARRIER SAFETY REGULATIONS HANDBOOK (FMCSR)** as prescribed by U.S. DEPARTMENT OF TRANSPORTATION **FEDERAL HIGHWAY ADMINISTRATION PARTS 393 & 396**, and **NORTH AMERICAN UNIFORM OUT-OF-SERVICE CRITERIA, COMMERCIAL VEHICLE SAFETY ALLIANCE (CVSA)**.

REJECT IF: Parts and accessories covered in FMCSR part 393, 396 and/or CVSA North American Uniform Out-of-Service Criteria are not in safe and proper operating conditions at all times. These include, but are not limited to the parts and accessories listed below.

2. Gauges and Lights (393.81, 393.9)

- Speedometer inoperative.
- All required lighting devices, reflectors and electrical equipment must be properly positioned, colored and working.

3. Seat Belts (393.93)

- Any driver or right outboard seat belt missing or inoperative.

4. Glass and Mirrors (393.60, 393.80)

- Any discoloration not applied by the manufacturer for reduction of glare.
- Any windshield crack over 1/4" wide.
- Any crack less than 1/4" wide that intersects with any other crack.
- Any damage 3/4" or greater in diameter.
- Any 2 damaged areas closer than 3" to each other.
- Any required mirror missing. One on each side, firmly attached to the outside of the vehicle, and so located as to reflect to the driver a view of the highway to the rear along both sides of the vehicle.
- Any required mirror broken. (396.3(A)(1)).

5. Wipers and Horn (393.78, 393.81)

- Wiper blade(s) fail to clean windshield within 1" of windshield sides.
- Horn missing, inoperative or fails to give adequate/reliable warning signal.

10. Fuel System (393.65, 393.67)

- Fuel tank not securely attached to vehicle by reason of loose, broken or missing mounting bolts or brackets.
- Visible leak at any point.
- Fuel tank cap missing.

14. Steering (393.209)

- Steering wheel does not turn freely, has any spokes cracked through or is missing any parts.
- Steering lash not within parameters, see chart in FMCSR 393.209.
- Steering column is not secure.
- Steering system: any U-joint worn, faulty or repaired by welding.
- Steering gear box is loose, cracked or missing mounting bolts.
- Pitman arm is loose, or has any welded repairs.
- Power Steering: any component is inoperative. Any loose, broken or missing parts. Belts frayed, cracked or slipping.
- Any fluid leaks, fluid reservoir not full.

15. Brakes (393.40-393.53)

- Brake system has any deficiencies as described in FMCSR.
- Brake system has any missing, loose, broken, out of adjustment or worn out components.
- Brake system failure warning device missing, inoperative, or fails to give adequate warning.
- Brake system has any air or fluid leaks. (396.3(a)(1)).

18. Springs and Shocks (393.207)

- Any axle positioning part is cracked, broken, loose or missing. All axles must be in proper alignment.
- Any leaf spring cracked, broken, missing or shifted out of position.
- Adjustable axle assemblies with locking pins missing or not engaged.

20. Exhaust (393.83)

- Any part of the exhaust system so located as would be likely to result in charring, burning, or damaging the wiring, fuel supply or any combustible part of the vehicle.
- Bus exhaust leaks or discharge forward of the rearmost part of the bus in excess of 6" for Gasoline powered or 15" for other than Gasoline powered, or forward of any door or window designed to be opened on other than a Gasoline powered bus. (Exception: emergency exit)
- Any leak at any point forward of or directly below the driver and/or sleeper compartment.

21. Frame (393.201)

- Any cracked, broken, loose or sagging frame member.
- Any loose or missing fasteners including those attaching engine, transmission, steering gear, suspension, body, and fifth wheel.
- Any condition that causes the body or frame to contact the tire or wheel assemblies. (396.3(a)(1))

22. Tires and Wheels (393.75, 393.205)

- Any body ply or belt material exposed through tread or sidewall.
- Any tread or sidewall separation.
- Any cut exposing ply or belt material.
- Tread depth less than 4/32" on steering axle.
- Less than 2/32" on any other axle.
- Any bus with regrooved, recapped, or retreaded tires on the front wheels.
- Any tire not properly inflated or any overloaded tire.
- Any tire that comes in contact with any part of the vehicle. (393.3(a)(1))
- Any tire marked "Not for Highway Use". (393.3(a)(1))
- Wheels and rims shall not be cracked or broken.
- Stud or bolt holes on the wheels shall not be elongated.
- Nuts or bolts shall not be missing or loose.

24. Emergency Equipment (393.95)

- Every power unit must be equipped with a fire extinguisher that is properly filled and readily accessible for use. (393.95(a))
- At least one spare fuse or other overload protective device. (393.95(c))
- Warning devices for stopped vehicles. (393.95(f,g))

25. License (383.23, 391.41)

- No person shall operate a commercial motor vehicle unless such person has passed written and driving tests which meet the Federal Standards for the commercial motor vehicle that person operates. (383.23(a))
- Persons shall not drive a commercial motor vehicle unless he/she is physically qualified to do so and, except as provided in 391.67, has on his/her person the original, or a photographic copy, of a medical examiner's certificate that he/she is physically qualified. (391.41(a))

IN ADDITION TO THE ABOVE:

Agency personnel reserve the right to reject any equipment due to any additional condition or combination of conditions that make the vehicle unsafe, unreliable, or may pose unreasonable damage to the environment, or will be unable to fully perform the duties for which the equipment has been hired.

The Inspector shall inspect for compliance with the FMCSR, State and Local laws and regulations. Therefore, the Inspector is responsible to ACCEPT or REJECT all equipment he/she inspects.

Section IV, Item 23 - Truck, Bus, Van, Pickup, Body Condition Inspection

11

Pre-use Inspection

Release Inspection

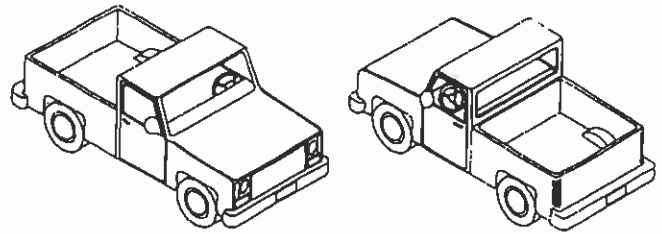
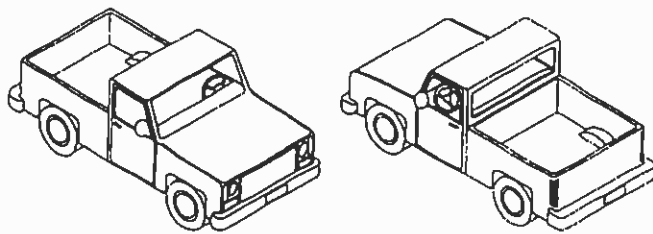
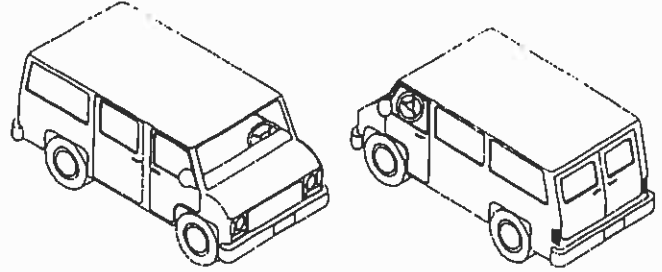
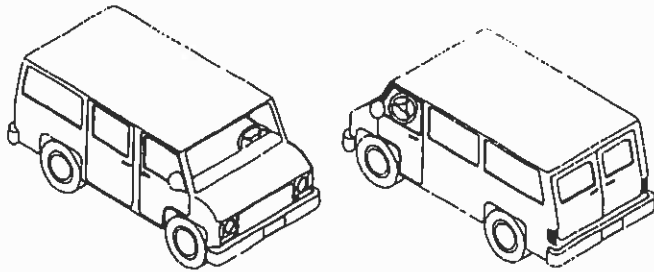
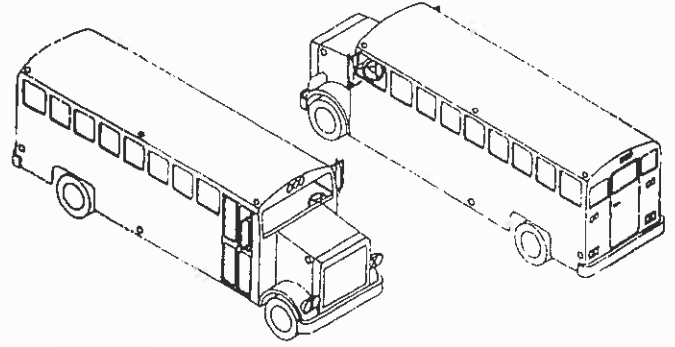
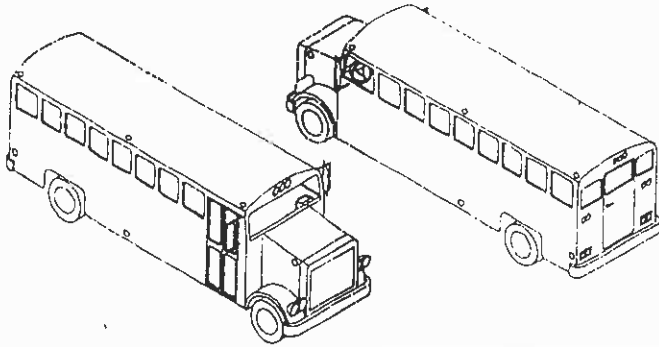
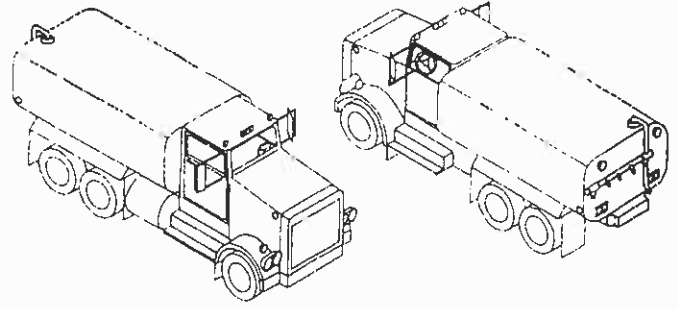
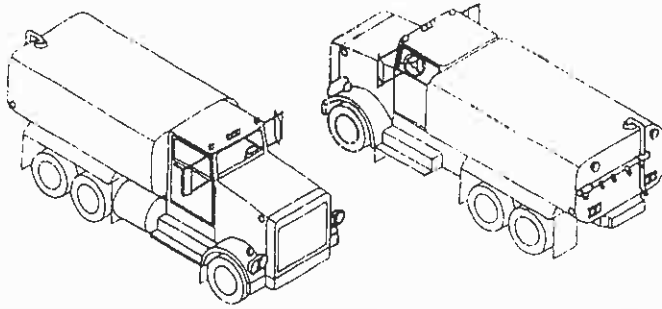

Remarks