

Model No: 3420

Model No:

Drawing No:

Customer :

H 520 PLUS

Rev. Date:

H 520 PLUS

Service Manual

Created by:

Approved by:

Rev.No:

For Stage:

Release Date:

Page: 1 Of 57



Model No: 3420

Model No:

Drawing No:

Customer :

H 520 PLUS

Rev. Date:

Table of Contents

	Page
Specifications	3
Test and Alignment Procedure	8
Block Diagram	13
Schematic Diagram	14
Printed Circuit Board	23
Channel Frequency Charts	25
Parts List	40
Semiconductor Voltage Chart	45
Semiconductor Lead Assignment and Block Diagram	53
Exploded View Parts List	56
Exploded View	57

Created by:

Approved by:

Rev.No:

For Stage:

Release Date:

Page: 2 Of 57



Model No: 3420

Model No:

Drawing No:

Customer :

H 520 PLUS

Rev. Date:

SPECIFICATIONS

1. GENERAL

Channels..... 400 Ch AM/ FM 4W
Frequency Range.....25.615 to 30.105 MHz
FrequencyControl.....PLL
Operating Temperature Range.....-10° / + 50°C
DC Input Voltage.....9.0 V DC ±15%
Size.....140(L) X 60(W) X 30(H) mm
Weight.....0.50 kg

2. RECEIVER

Receiving System.....Dual Conversion Super Heterodyne
Intermediate Frequency.....1st IF: 10.695 MHz, 2nd IF: 455 MHz
Sensitivity.....0.5 µV for 20 db SINAD in FM mode
Audio Distortion.....Less Than 8% @ 1 KHz
Image Rejection.....60 dB
Adjacent Channel Rejection.....60 dB
Signal/ Noise Ratio.....45 dB
Current Drain at standby.....60 mA

3. TRANSMITTER

Output Power.....4W @ 9.0 V DC
Modulation.....FM: 1.6 KHz ±0.2 KHz
Frequency response.....From 300 Hz to 3.0 KHz
Output impedance.....RF 50 ohm Unbalance
Signal/ Noise Ratio.....40 dB MIN
Current Drain.....1300 mA

Created by:

Approved by:

Rev.No:

For Stage:

Release Date:

Page: 3 Of 57



Model No: 3420

Model No:

Drawing No:

Customer :

H 520 PLUS

Rev. Date:

OPERATION INSTRUCTIONS

Having properly installed your batteries and hooked-up the antenna, you are now ready to operate your radio for optimum reception and voice transmission.

Turn the power "ON" with ON/OFF switch.

Set the desired channel.

Adjust the squelch control knob to reduce any undesirable background noise when no signal is being received. To do this, select a channel where no signal are present, or wait until signals cease on your channel. Then, rotate the squelch control knob clockwise to a point where the background noise disappears.

Note: When the squelch is set properly, the speaker will remain quiet until a signal is received. In order to receive weak signals, do not set the squelch too high.

Adjust the volume to the desired listening level.

To Transmit

Press and hold the push-to-talk button. Speak slowly and clearly in a normal voice two to three inches from the microphone. A built-in modulation control circuit will automatically adjust the microphone input level. There is no need to speak loudly.

To Receive

Release the push-to-talk button.

Created by:

Approved by:

Rev.No:

For Stage:

Release Date:

Page: 4 Of 57

THEORY OF OPERATIONS

TRANSMITTER

A. RF Amplification

The output of double AMP Q201 is fed through tuning T203 and T204 to the base of pre driver AMP Q202. The output is then supplied to RF driver AMP Q203. The output of Q203 is supplied with tuning circuit L204 and C214, C215, C216 and goes to the base of final RF AMP Q204. The output of Q204 is supplied to the antenna through L-C tuning circuit.

B. Circuit for Suppression of Spurious Radiation

The tuning circuit between the output of final AMP Q204 and antenna, 5-stage "PHI" network C221, C219, C220, L206, C223, C245, L207, C241, C228, C240, L208, C242, C230, C229, L209, C234, C233, C232, L210, C243, C235, C236 serves as a spurious radiation suppressor . This network also serves to match the impedance between TX power AMP Q204 and the antenna.

C. Circuit for Limiting Power

After finished all alignment, the constant voltage supply circuit limits the available power 4 W or slightly less. RV501 and corresponding three transistors Q509, Q502, Q501 control supply voltage of RF amplifier and other circuits.

Tune all the trimmer parts for maximum indication of RF power meter and adjust RV501 to make 4 w indication of RF power meter.

The tuning is adjusted so that the actual power is from 3.8 to 4.0 W. There are no other additional controls for adjusting the TX output power.

D. Modulation Control

a. FM

The mic input is fed to audio amplifier IC KIA324 which drives modulation varicap diode D302 in the VCO circuit. RV701 limits the incoming modulation audio levels to inhibit over modulation. While reading the modulation factor on the modulation analyzing equipment, adjust RV701 shall not exceed +/-1.6 KHz/Dev. After 20 dB up from 1.25 KHz/1.2 KHz/Dev. Audio level

b. AM

Created by:	Approved by:	Rev.No:
For Stage:	Release Date:	Page: 5 Of 57



Model No: 3420

Model No:

Drawing No:

Customer :

H 520 PLUS

Rev. Date:

Modulation signal is fed to audio amplifier IC KIA324 and goes to TX voltage regulate circuit Q509, Q502, Q501 to make nominal signal level to achieve wanted modulation. To control incoming audio signal, R272 and corresponding ALC circuit limits the modulation shall not exceed +/-60% adjust RV702 +/-60% modulation under 1.0 KHz AF 60% mod plus 20 dB of audio signal.

E. Receiver

CB receiver is dual conversion supper-heterodyne type with the first IF 10.695 MHz and second IF 455 KHz. Receiver is separated two blocks, 1st IF section and 2nd IF section.

The PLL synthesizer supplies first local frequency 16.270 ~ 16.710 MHz.(for EU) and 16.90625 MHz ~ 17.29625 MHz (for UK) With the provided first local frequencies Q102,Q103 mixes the incoming RF signal to generate first IF signal. Mixed signals were filtered with the CF101 (10.695 MHz) crystal filter and other tuning circuits. Output signal of mixer is filtered with CF102 (455 KHz ceramic filter). The 455 KHz signal from the 2nd IF filter was amplified and limits internally. After amplification the signals fed the quadrature detector loop T104. Then we can see the recovered audio signals on Pin 12 for FM and Pin 13 for AM of IC1.

Created by:

Approved by:

Rev.No:

For Stage:

Release Date:

Page: 6 Of 57

TROUBLE SHOOTING HINTS

Symptom	Probable Cause	Remedy
Unit does not work at all	<ul style="list-style-type: none"> • Defective power switch VR601. • Empty Battery. • Broken wire Battery. • Defective D501. 	<ul style="list-style-type: none"> • Replace • Replace • Replace • Replace
No output from speaker at all	<ul style="list-style-type: none"> • Defective external speaker jack. • Wire speaker open. • Defective internal speaker. • Defective VR601, IC601, Q601 other components. 	<ul style="list-style-type: none"> • Repair or replace • Replace • Replace • Replace the defective components.
No noise on speaker	<ul style="list-style-type: none"> • Measure all the voltage of IC601,102 with voltage chart • Defective squelch circuit components (RV101, VR102, IC102) 	<ul style="list-style-type: none"> • Replace • Replace
Squelch does not work	<ul style="list-style-type: none"> • Defective VR102, RV101, IC102. 	<ul style="list-style-type: none"> • Replace the defective components. • Re-adjust
No modulation	<ul style="list-style-type: none"> • Defective RV702. • Defective microphone or EXT microphone jack. • Poor audio output and defective modulation microphone amplifier components (IC103). • Defective microphone wire connector. 	<ul style="list-style-type: none"> • Replace • Replace • Replace the defective components. • Replace
LCD display does not work	<ul style="list-style-type: none"> • Defective LED. • Defective Q803. 	<ul style="list-style-type: none"> • Replace • Replace

ALIGNMENT PROCEDURE

Step	Setting	Connection	Adjuster	Adjust for
1	Frequency adjustment MIC : Receive Volume : optional Squelch : optional CH selector : 19	Frequency counter to dummy load (Figure 1).	X302	27.185MHz±300Hz
2	VCO Voltage adjustment MIC : Receive Volume : optional Squelch : optional CH selector : 19	Connect DC voltmeter at test point1 (Figure 2).	T302	1.4V at RX.

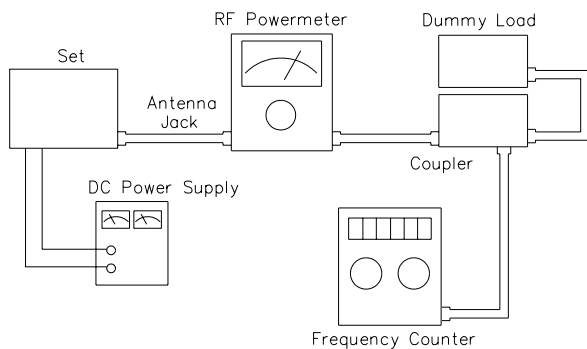

Figure 1

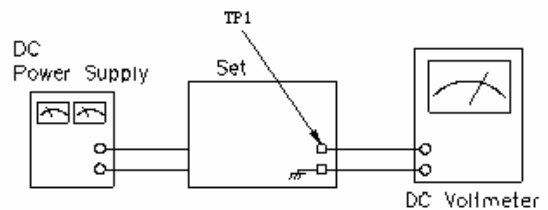

Figure 2

TRANSMITTER SECTION**Test Equipment Required**

- RF power meter (RF SSVM)
- 50 ohms dummy load (non-inductive)
- RF attenuator (50 ohms non-inductive)
- Oscilloscope
- Audio generator
- DC power supply (9.0 volt, 3 amp)
- Spectrum analyzer
- Frequency counter
- Coupler

ALIGNMENT PROCEDURE

Step	Setting	Connection	Adjuster	Adjust for
1	RF power stage MIC : Transmit Volume : optional Squelch : optional CH : selector : 19	Connect dummy load and RF power meter to the EXT-ANT jack on the set (Figure 3).	T203 T204	Maximum indication on the power meter (4 watts). If indication is not in 4 watts range, adjust T203, T204.
2	Second harmonic check MIC : Transmit Volume : optional Squelch : optional CH : selector : 19	Connect RF power meter With dummy load to spectrum analyzer through coupler /-40 dB Attenuator to EXT-ANT jack on the set (Figure 4).		At no modulation, compare the level o fundamental frequency to the level of harmonic frequency. Suppression of the 2 nd harmonic frequency level must be
3	Frequency check MIC : Transmit Volume : optional Squelch : optional CH : selector : 19	Connect dummy load and frequency counter though coupler to RF power meter. Connect RF power meter to EXT-ANT jack on the set (Figure 5).	X302	Be sure that the indication of the transmitter frequency is 27.185MHz±300Hz on the frequency counter.
4	TX power adjustment Volume : optional Squelch : optional CH : selector : 19	Connect dummy load and oscilloscope through Coupler to RF power meter connect audio generator to microphone jack (Figure 6).	RV501	Adjust until 3.6-4 Watts

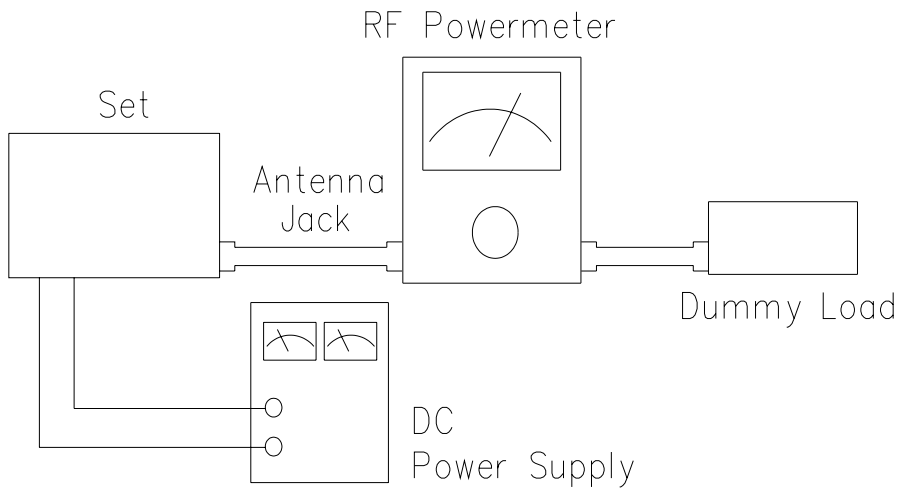

Figure 3

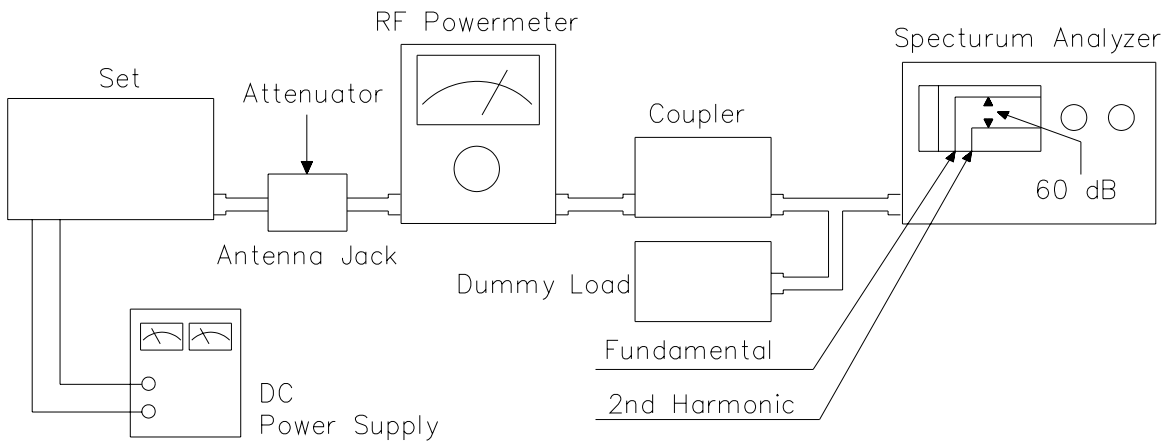

Figure 4

RECEIVER SECTION**Test Equipment Required**

- RF Signal generator (RFSG)
- SSVM
- Distortion meter
- DC power supply

ALIGNMENT PROCEDURE

Step	Setting	Connection	Adjuster	Adjust for
1	Audio output adjustment MIC : Receive Volume : Fully clockwise Squelch: Turn to- Counter clockwise CH selector : 19 RFSG:27.185 MHz,1kHz 1 μ V , 1.2 K Dev.	Connect RF signal generator to EXT-ANT jack. Connect SSVM and distortion meter with 8 ohm dummy load (Figure 7).	T102 T103	Maximum indication on SSVM. Reduce output from RFSG until the audio output becomes about 600mV.
2	Squelch adjustment MIC : Receive Volume : 600mV Squelch : Clockwise CH selector : 19 RFSG:27.185MHz, 1kHz 1mV, 1.2K DEV.	Connect RF signal generator to EXT-ANT Jack. Connect SSVM and distortion meter to EXT speaker jack with 8 ohm dummy load (Figure 7).	RV101	Adjust until the audio output appears.
3	Auto Squelch adjustment MIC : Receive Volume : 600mV Squelch : Auto Squelch on CH selector : 19 RFSG:27.185MHz, 1kHz 1uV, 1.2K DEV.	Connect RF signal generator to EXT-ANT Jack. Connect SSVM and distortion meter to EXT speaker jack with 8 ohm dummy load (Figure 7).	RV103	Adjust until the audio output disappears.

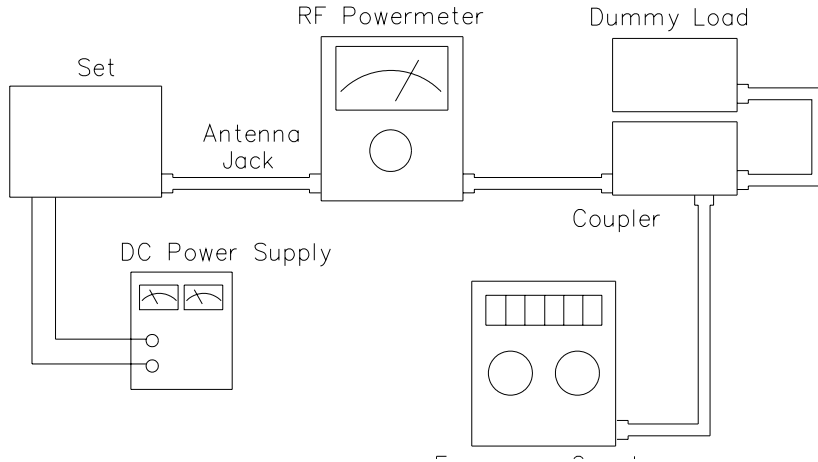

Figure 5

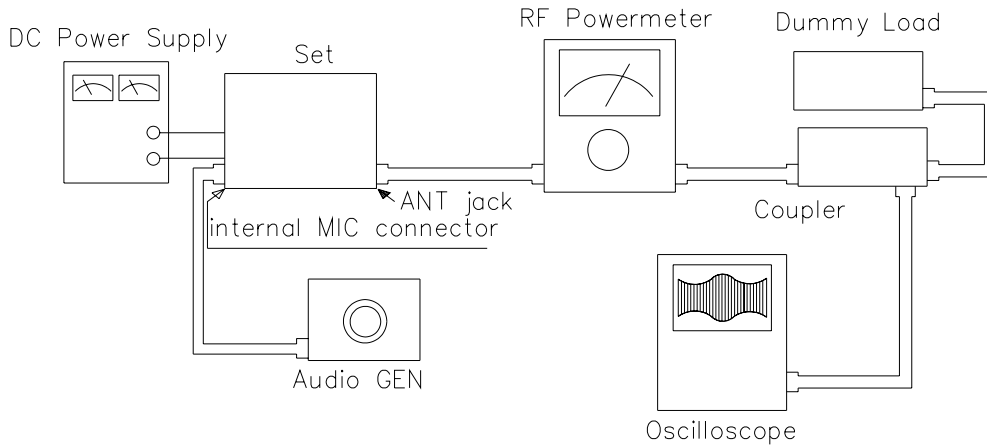

Figure 6

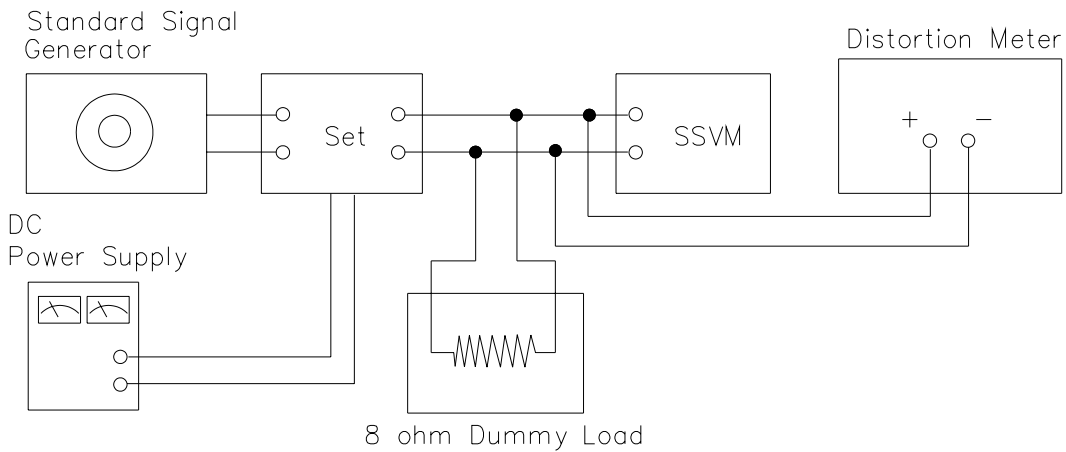
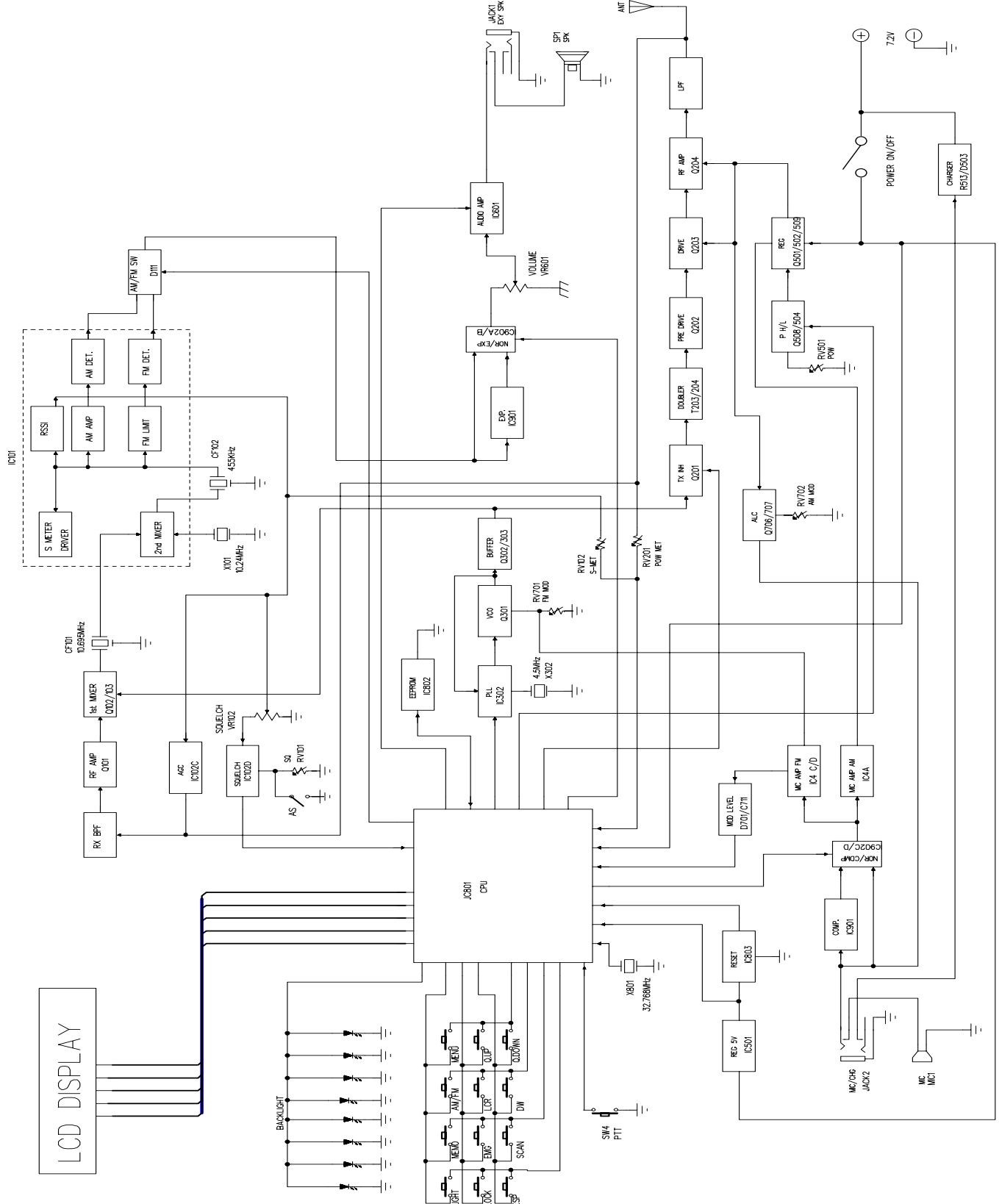
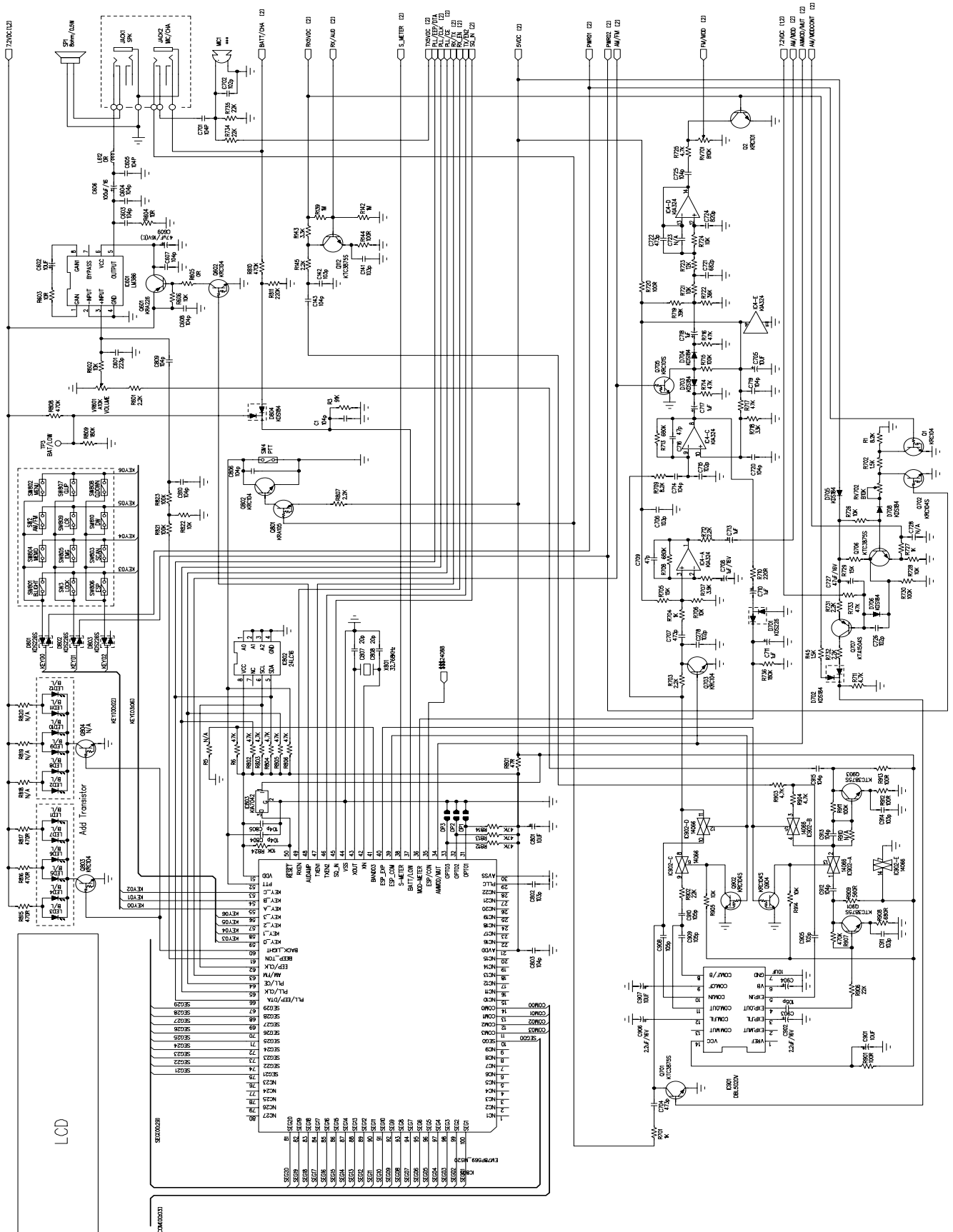

Figure 7





Model No: 3420
Customer :

Model No:
H 520 PLUS

Drawing No:
Rev. Date:

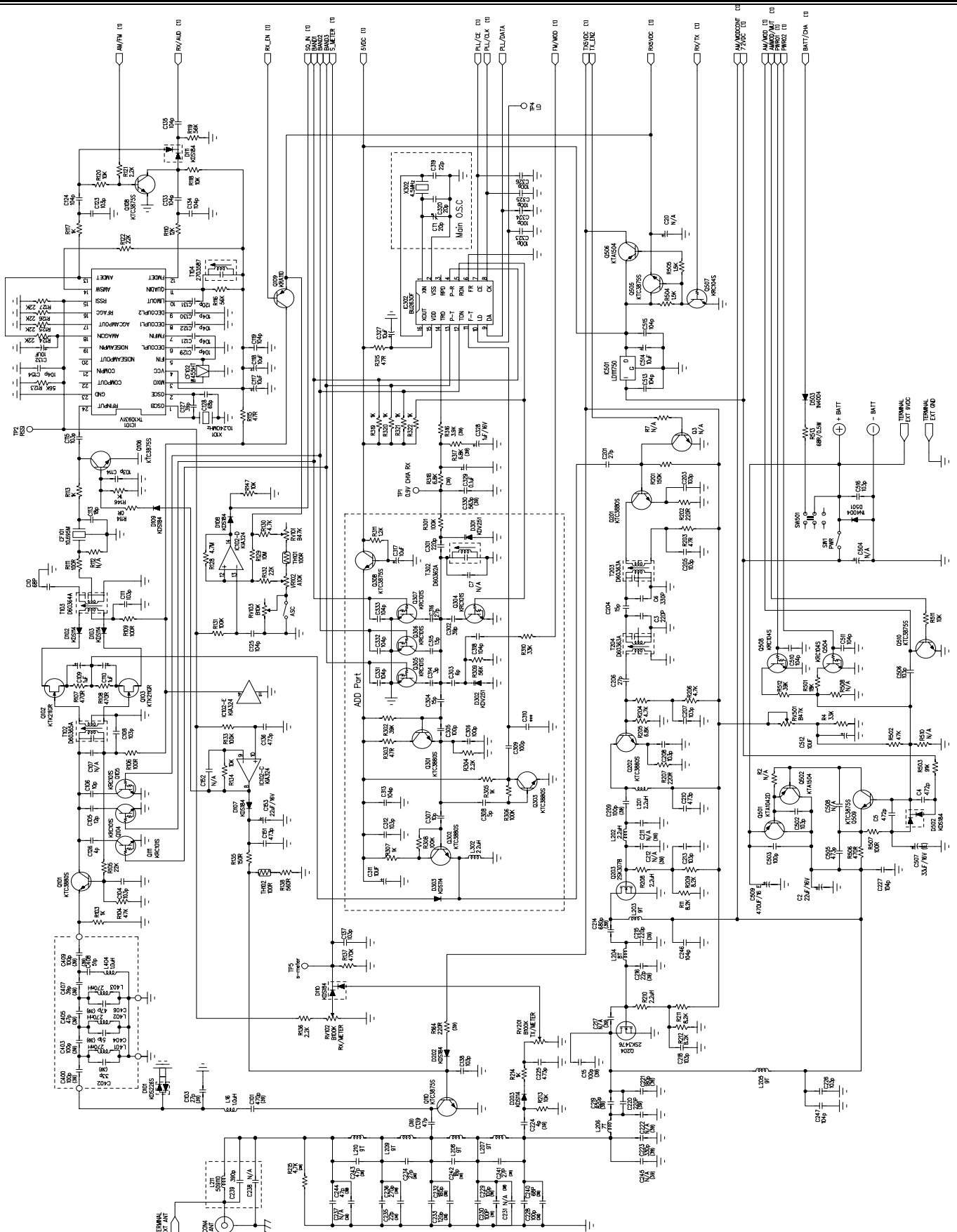

Created by:
For Stage:

Approved by:
Release Date:

Rev.No:
Page: 15 Of 57

PLL CIRCUIT BLOCK DIAGRAM**1. INTRODUCTION**

The frequencies for transmitter and receiver first local frequencies are all derived from a single 10.240 MHz crystal by means of a phase locked loop. The first local oscillator frequencies are 16.270 MHz (CH 1) to 16.710 MHz (CH 40) for EU and 16.90625 MHz (CH 1) to 17.29625 MHz (CH 40) for UK. The second local frequency is fixed at 10.240 MHz to generate second IF 455 KHz. During transmit, The VCO of the PLL operates 13.4825 MHz (CH 1) to 13.7025 MHz (CH 40) for EU, 13.800625 MHz (CH 1) to 13.995625 MHz (CH 40) for UK the VCO frequency goes to the double circuit Q201, T203, T204 which doubles the frequency to generate 26.965 MHz (CH 1) to 27.405 MHz (CH 40) for EU and 27.60125 MHz (CH 1) to 27.99125 MHz (CH 40) for UK

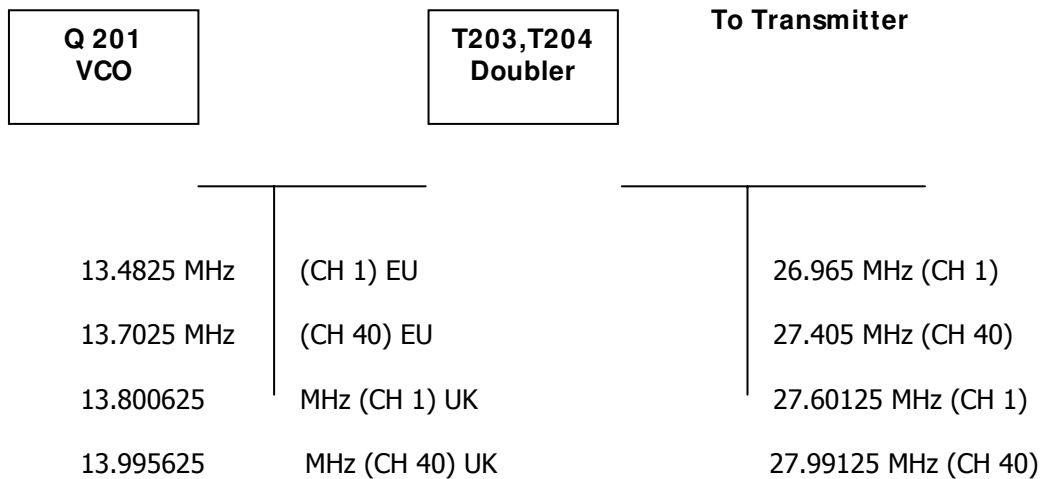

The VCO operating frequency for the receiver is 16.270, 16.90625 MHz (CH 1) to 16.710, 17.29625 MHz (CH 40) as the first local oscillator, injected through the buffer AMP Q302 into the first fed balanced mixer Q102, Q103.

2. BASIC SYNTHESIZER SCHEME

The crystal frequency (10.240MHz) is divided by 1800 times to make 2.5 KHz which is fed to one side of the phase detector. The VCO output is divided by a programmable divider, and fed to other side of the phase detector Pin 11 of IC302. The feedback loop is closed by passing the phase detector output through an active low pass filter and using the output to control the VCO frequency through varicap diode D301.

Under locked conditions, both of phase detector input signal must be identical at 2.5 KHz. The VCO frequency is then given by:

$$FVCO / N = 0.0025 \text{ MHz} \quad \text{or} \quad FVCO = 0.0025 \times N \text{ MHz}$$

Since "N" is an integer, the VCO frequency can be stepped up with 2.5 KHz increments. By suitable choice of "N" the desired output frequency can be obtained.

	Channel 1		Channel 40		Function
	N	FVCO	N	FVCO	
Transmit	5393	13.4825	5481	13.7025	EU
Receive	6508	16.2700	6684	16.7100	
Transmit	5520.25	13.800625	5598.25	13.995625	UK
Receive	6762.50	16.90625	6918.5	17.29625	

(SEE TABLE FOR OTHER CHANNELS)

Created by:	Approved by:	Rev.No:
For Stage:	Release Date:	Page: 17 Of 57

The VCO frequency goes to the double circuit, which doubles the incoming signals.

		Double output Frequency
Transmit _____	CH 1, 13.4825 MHz CH 1, 13.800625 MHz	26.965 MHz 27.60125 MHz
Transmit _____	CH 40, 13.7025 MHz CH 40, 13.995625 MHz	27.405 MHz 27.99125 MHz

Since all frequencies are obtained from the crystal controlled PLL oscillator, all outputs are coherent with the

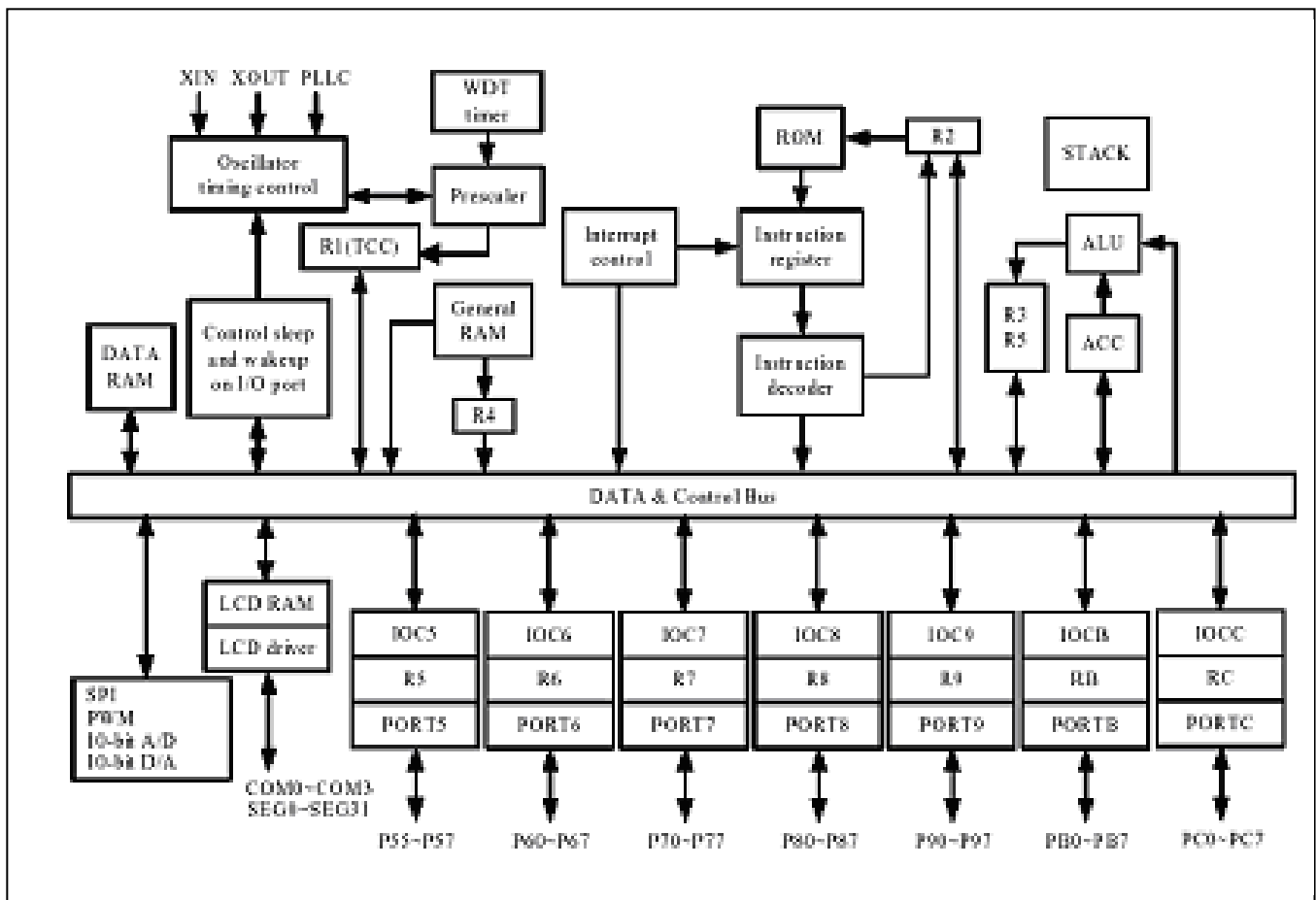

crystal oscillator frequency and maintaining the same percentage accuracy.

INTERNAL BLOCK DIAGRAM



Model No: 3420

Model No:

Drawing No:

Customer :

H 520 PLUS

Rev. Date:

DIVIDE RATIO, VCO RX/TX FREQUENCIES FOR EACH CHANNEL OF "EU"

Channels	Frequencies (MHz)	RX		TX	
			Frequencies MHz		Frequencies MHz
1	26.965	6508	16.27	5393	13.4825
2	26.975	6512	16.28	5395	13.4875
3	26.985	6516	16.29	5397	13.4925
4	27.005	6524	16.31	5401	13.5025
5	27.015	6528	16.32	5403	13.5075
6	27.025	6532	16.33	5405	13.5125
7	27.035	6536	16.34	5407	13.5175
8	27.055	6544	16.36	5411	13.5275
9	27.065	6548	16.37	5413	13.5325
10	27.075	6552	16.38	5415	13.5375
11	27.085	6505	16.39	5417	13.5425
12	27.105	6512	16.41	5421	13.5525
13	27.115	6516	16.42	5423	13.5575
14	27.125	6524	16.43	5425	13.5626
15	27.135	6528	16.44	5427	13.5675
16	27.155	6532	16.46	5431	13.5775
17	27.165	6536	16.47	5433	13.5825
18	27.175	6544	16.48	5435	13.5875
19	27.185	6548	16.49	5437	13.5925
20	27.205	6552	16.51	5441	13.6025
21	27.215	6608	16.52	5443	13.6075
22	27.225	6612	16.53	5445	13.6125
23	27.255	6624	16.56	5451	13.6275
24	27.235	6616	16.54	5447	13.6175
25	27.245	6620	16.55	5449	13.6225
26	27.265	6628	16.57	5453	13.6325
27	27.275	6632	16.58	5455	13.6375
28	27.285	6636	16.59	5457	14.6425
29	27.295	6640	16.60	5459	13.6475
30	27.305	6644	16.61	5461	13.6525
31	27.315	6648	16.62	5463	13.6575
32	27.325	6652	16.63	5465	13.6625
33	27.335	6656	16.64	5467	13.6675
34	27.345	6660	16.65	5469	13.6725
35	27.355	6664	16.66	5471	13.6775
36	27.365	6668	16.67	5473	13.6825
37	27.375	6672	16.68	5475	13.6875
38	27.385	6676	16.69	5477	13.6925
39	27.395	6680	16.70	5479	13.6975
40	27.405	6684	16.71	5481	13.7025

Created by:	Approved by:	Rev.No:
For Stage:	Release Date:	Page: 19 Of 57



Model No: 3420

Model No:

Drawing No:

Customer :

H 520 PLUS

Rev. Date:

DIVIDE RATIO, VCO RX/TX FREQUENCIES FOR EACH CHANNEL OF "UK"

Channels	Frequencies (MHz)	RX		TX	
			Frequencies MHz		Frequencies MHz
1	27.60125	6546.5	16.90625	5412.25	13.800625
2	27.61125	6766.5	16.91625	5522.25	13.805625
3	27.62125	6770.5	16.92625	5524.25	13.810625
4	27.63125	6774.5	16.93625	5526.25	13.815625
5	27.64125	6778.5	16.94625	5528.25	13.820625
6	27.65125	6782.5	16.95625	5530.25	13.825625
7	27.66125	6786.5	16.96625	5532.25	13.830625
8	27.67125	6790.5	16.67625	5534.25	13.835625
9	27.68125	6794.5	16.98625	5536.25	13.840625
10	27.69125	6798.5	16.99625	5538.25	13.845625
11	27.70125	6802.5	17.00625	5540.25	13.850625
12	27.71125	6806.5	17.01625	5542.25	13.855625
13	27.72125	6810.5	17.02625	5544.25	13.860625
14	27.73125	6814.5	17.03625	5546.25	13.865625
15	27.74125	6818.5	17.04625	5548.25	13.870625
16	27.75125	6822.5	17.05625	5550.25	13.875625
17	27.76125	6826.5	17.06625	5552.25	13.880625
18	27.77125	6830.5	17.07625	5554.25	13.885625
19	27.78125	6834.5	17.08625	5556.25	13.890625
20	27.79125	6838.5	17.09625	5558.25	13.895625
21	27.80125	6842.5	17.10625	5560.25	13.900625
22	27.81125	6846.5	17.11625	5562.25	13.905625
23	27.82125	6850.5	17.12625	5564.25	13.910625
24	27.83125	6854.5	17.13625	5566.25	13.915625
25	27.84125	6858.5	17.14625	5568.25	13.920625
26	27.85125	6861.5	17.15625	5570.25	13.925625
27	27.86125	6866.5	17.16625	5572.25	13.930625
28	27.87125	6870.5	17.17625	5574.25	13.935625
29	27.88125	6874.5	17.18625	5576.25	13.940625
30	27.89125	6878.5	17.19625	5578.25	13.945625
31	27.90125	6882.5	17.20625	5580.25	13.950625
32	27.91125	6886.5	17.21625	5582.25	13.955625
33	27.92125	6890.5	17.22625	5584.25	13.960625
34	27.93125	6844.5	17.23625	5586.25	13.965625
35	27.94125	6898.5	17.24625	5588.25	13.970625
36	27.95125	6902.5	17.25625	5590.25	13.975625
37	27.96125	6906.5	17.26625	5592.25	13.980625
38	27.97125	6910.5	17.27625	5594.25	13.985625
39	27.98125	6914.5	17.28625	5596.25	13.990625
40	27.99125	6918.5	17.29625	5598.25	13.995625

Created by:

Approved by:

Rev.No:

For Stage:

Release Date:

Page: 20 Of 57

3. DESCRIPTIONS OF EACH BLOCK

A. Introduction

The synthesizer is implemented with the following

Components:

- PLL IC (IC302)
- X-TAL (X302)
- VCO, VARICAP DOIDE (D301)

IC302 is a cmos LSI that includes most of PLL block and driver, the Q301, C305, C306, C304, C301 and T302, Varicap diode D301 are clapp oscillator circuit to operate as a VCO of the IC302. Q301 is a switching transistor to connect or disconnect the tuning capacitor in the VCO oscillator tank circuit for transmitter or receiver. Q304 works as a buffer AMP for RX local frequencies (16 MHz) and TX generating frequencies (13 MHz).

B. Reference frequency

The crystal, X302 (4.50 MHz) and other components of IC302 can make a reference frequency oscillator with internal amplifier.

C. VCO

Q301 and surrounding parts are consisting a clapp oscillator works as a VCO of IC302. the VCO can be oscillate over the required of 13.4825 MHz to 17.29625 MHz

D. Phase detector and VCO control

The detector is a digital phase comparator which compares the phase of the reference signal with programmable divider output square waves and develops a series of pulses whose DC level depends on the phase error of each signal.

E. Transmitter/Receiver buffer AMP

Output signal of Q301 is fed into buffer AMP Q302,

F. Transmitter doubler

The output signals of Q302 goes to an amplifier with tuning circuit Q201, T203, T204 which doubles incoming 13 MHz signals.

G. Switching of tuning capacitor in VCO

The VCO circuit must tune with a wide rang of frequencies 13.4825 ~ 13.7025 MHz (EU), 13.800625 ~ 13.995625 MHz (UK) for transmitter and 16.270~16.710 MHz (EU), 16.90625 ~ 17.29625 MHz (UK) for receiver. To comply above range of VCO, the tuning capacitance should switched for transmission or reception.

H. Receiver local oscillator outputs

First Mixer:

The secondary output signals is injected to the sources of 1st mixer Q102, Q103 in the 1st IF mixer section

Second Mixer:

The output of 10.24 MHz oscillator circuit with X101 is injected into the IF IC internally. Incoming IF signal and 10.24 MHz are mixed inside the IF IC to extract 2nd IF signal 455 KHz. FM,AM audio signals are recovered with the way of quadrature detector, AM signals are recovered with envelope detector.

4. FREQUENCY STABILITYLET: F_o = Crystal oscillator frequency F_r = Phase detector reference frequency F_{vco} = VCO frequency F_t = Transmit frequencyThen: $F_r = F_o/1800$ And under locked conditions: $F_r = F_{vco} / N$

WHERE, "N" is the programmable divider divide ratio.

THEN: $F_{vco} = N \times F_r$

From which it can be seen, the percentage error in F_t is the same as the percentage error in F_o . The stability of the crystal oscillator is determined primarily by the crystal itself and having lesser deviation by the active and passive components of the oscillator. The choice of crystal and component is such that the required frequency stability is maintained over the required voltage and temperature rang.

Model No: 3420
Customer :

Model No:
H 520 PLUS

Drawing No:
Rev. Date:

Printed Circuit Board

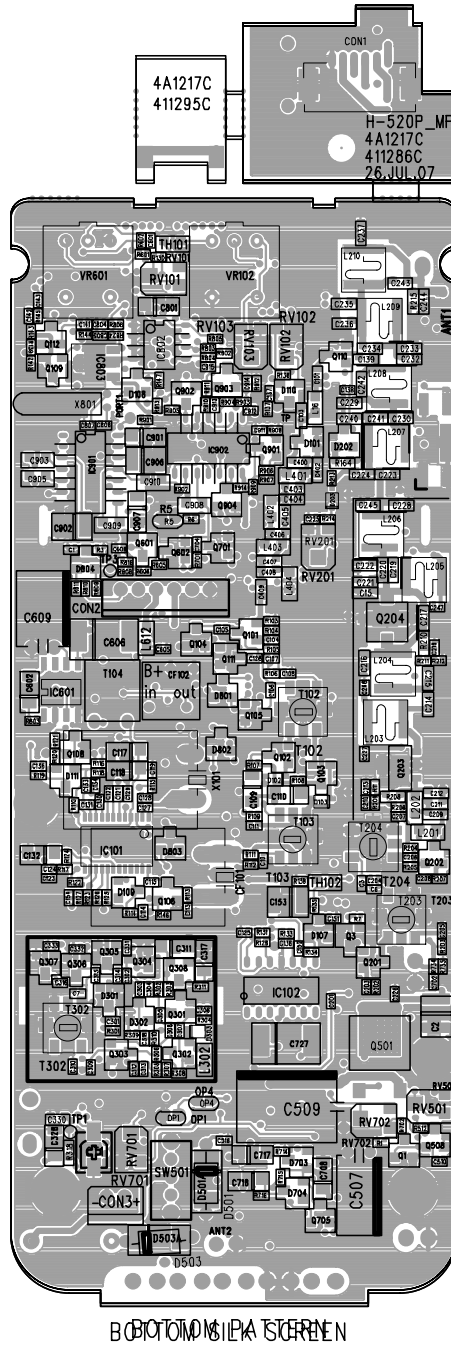

B (BOTTOM) SIDE SCREEN

Created by:
For Stage:

Approved by:
Release Date:

Rev.No:
Page: 23 Of 57

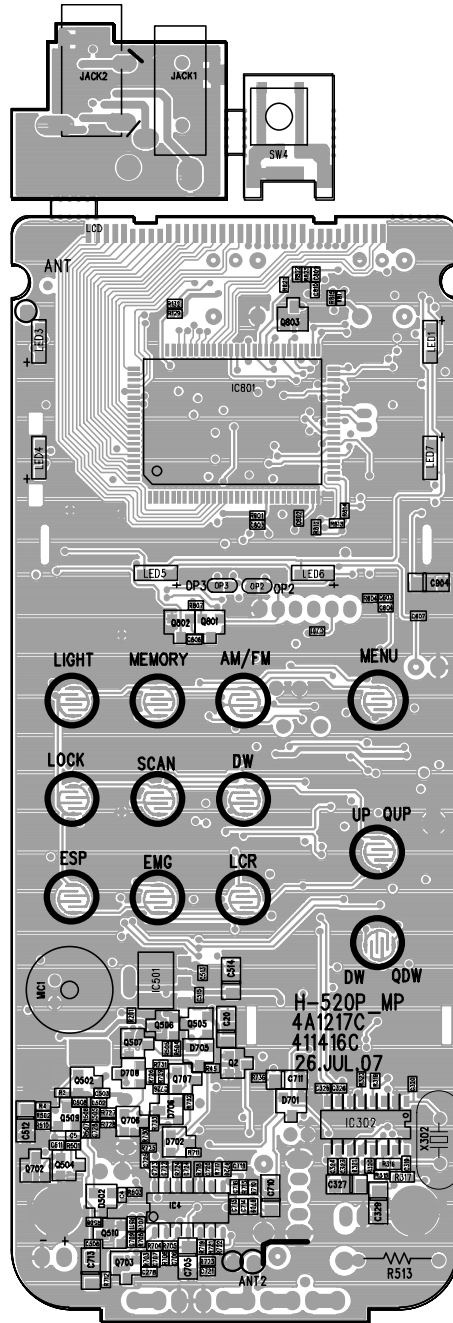

H-520P_MP
4A1217C
411416C
26 JUL 07



Model No: 3420

Model No:

Drawing No:

Customer :

H 520 PLUS

Rev. Date:

FREQUENCY TABLE FOR EUROPEAN

1. Frequencies for E1 band (Italy 40CH AM / FM 4W)

CH	Frequency (MHz)	Modulation	CH	Frequency (MHz)	Modulation
1	26.965	AM / FM	21	27.215	AM / FM
2	26.975	AM / FM	22	27.225	AM / FM
3	26.985	AM / FM	23	27.255	AM / FM
4	27.005	AM / FM	24	27.235	AM / FM
5	27.015	AM / FM	25	27.245	AM / FM
6	27.025	AM / FM	26	27.265	AM / FM
7	27.035	AM / FM	27	27.275	AM / FM
8	27.055	AM / FM	28	27.285	AM / FM
9	27.065	AM / FM	29	27.295	AM / FM
10	27.075	AM / FM	30	27.305	AM / FM
11	27.085	AM / FM	31	27.315	AM / FM
12	27.105	AM / FM	32	27.325	AM / FM
13	27.115	AM / FM	33	27.335	AM / FM
14	27.125	AM / FM	34	27.345	AM / FM
15	27.135	AM / FM	35	27.355	AM / FM
16	27.155	AM / FM	36	27.365	AM / FM
17	27.165	AM / FM	37	27.375	AM / FM
18	27.175	AM / FM	38	27.385	AM / FM
19	27.185	AM / FM	39	27.395	AM / FM
20	27.205	AM / FM	40	27.405	AM / FM

Created by:

Approved by:

Rev.No:

For Stage:

Release Date:

Page: 25 Of 57



Model No: 3420

Model No:

Drawing No:

Customer :

H 520 PLUS

Rev. Date:

2. Frequencies for I2 band (Italy 36CH AM / FM 4W)

CH	Frequency (MHz)	Modulation	CH	Frequency (MHz)	Modulation
1	26.965	AM / FM	19	27.185	AM / FM
2	26.975	AM / FM	20	27.205	AM / FM
3	26.985	AM / FM	21	27.215	AM / FM
4	27.005	AM / FM	22	27.225	AM / FM
5	27.015	AM / FM	23	27.255	AM / FM
6	27.025	AM / FM	24	27.245	AM / FM
7	27.035	AM / FM	25	27.265	AM / FM
8	27.055	AM / FM	26	26.875	AM / FM
9	27.065	AM / FM	27	26.885	AM / FM
10	27.075	AM / FM	28	26.895	AM / FM
11	27.085	AM / FM	29	26.905	AM / FM
12	27.105	AM / FM	30	26.915	AM / FM
13	27.115	AM / FM	31	26.925	AM / FM
14	27.125	AM / FM	32	26.935	AM / FM
15	27.135	AM / FM	33	26.945	AM / FM
16	27.155	AM / FM	34	26.955	AM / FM
17	27.165	AM / FM	35	26.855	AM / FM
18	27.175	AM / FM	36	26.865	AM / FM

Created by:

Approved by:

Rev.No:

For Stage:

Release Date:

Page: 26 Of 57

Model No: 3420

Model No:

Drawing No:

Customer :

H 520 PLUS

Rev. Date:

3. Frequencies for DE band (Germany 80CH FM 4W 12CH AM 1W)

CH	Frequency (MHz)	Modulation
1	26.965	FM
2	26.975	FM
3	26.985	FM
4	27.005	AM / FM
5	27.015	AM / FM
6	27.025	AM / FM
7	27.035	AM / FM
8	27.055	AM / FM
9	27.065	AM / FM
10	27.075	AM / FM
11	27.085	AM / FM
12	27.105	AM / FM
13	27.115	AM / FM
14	27.125	AM / FM
15	27.135	AM / FM
16	27.155	FM
17	27.165	FM
18	27.175	FM
19	27.185	FM
20	27.205	FM
21	27.215	FM
22	27.225	FM
23	27.255	FM
24	27.235	FM
25	27.245	FM
26	27.265	FM
27	27.275	FM
28	27.285	FM
29	27.295	FM
30	27.305	FM
31	27.315	FM
32	27.325	FM
33	27.335	FM
34	27.345	FM
35	27.355	FM
36	27.365	FM
37	27.375	FM
38	27.385	FM
39	27.395	FM
40	27.405	FM

CH	Frequency (MHz)	Modulation
41	26.565	FM
42	26.575	FM
43	26.585	FM
44	26.595	FM
45	26.605	FM
46	26.615	FM
47	26.625	FM
48	26.635	FM
49	26.645	FM
50	26.655	FM
51	26.665	FM
52	26.675	FM
53	26.685	FM
54	26.695	FM
55	26.705	FM
56	26.715	FM
57	26.725	FM
58	26.735	FM
59	26.745	FM
60	26.755	FM
61	26.765	FM
62	26.775	FM
63	26.785	FM
64	26.795	FM
65	26.805	FM
66	26.815	FM
67	26.825	FM
68	26.835	FM
69	26.845	FM
70	26.855	FM
71	26.865	FM
72	26.875	FM
73	26.885	FM
74	26.895	FM
75	26.905	FM
76	26.915	FM
77	26.925	FM
78	26.935	FM
79	26.945	FM
80	26.955	FM

Created by:

Approved by:

Rev.No:

For Stage:

Release Date:

Page: 27 Of 57



Model No: 3420

Model No:

Drawing No:

Customer :

H 520 PLUS

Rev. Date:

4. Frequencies for D2 band (Germany 40CH FM 4W 12CH AM 1W)

CH	Frequency (MHz)	Modulation	CH	Frequency (MHz)	Modulation
1	26.965	FM	21	27.215	FM
2	26.975	FM	22	27.225	FM
3	26.985	FM	23	27.255	FM
4	27.005	AM / FM	24	27.235	FM
5	27.015	AM / FM	25	27.245	FM
6	27.025	AM / FM	26	27.265	FM
7	27.035	AM / FM	27	27.275	FM
8	27.055	AM / FM	28	27.285	FM
9	27.065	AM / FM	29	27.295	FM
10	27.075	AM / FM	30	27.305	FM
11	27.085	AM / FM	31	27.315	FM
12	27.105	AM / FM	32	27.325	FM
13	27.115	AM / FM	33	27.335	FM
14	27.125	AM / FM	34	27.345	FM
15	27.135	AM / FM	35	27.355	FM
16	27.155	FM	36	27.365	FM
17	27.165	FM	37	27.375	FM
18	27.175	FM	38	27.385	FM
19	27.185	FM	39	27.395	FM
20	27.205	FM	40	27.405	FM

Created by:

Approved by:

Rev.No:

For Stage:

Release Date:

Page: 28 Of 57



Model No: 3420

Model No:

Drawing No:

Customer :

H 520 PLUS

Rev. Date:

5. Frequencies for EU band (Europe 40CH FM 4W 40CH AM 1W)

CH	Frequency (MHz)	Modulation	CH	Frequency (MHz)	Modulation
1	26.965	AM / FM	21	27.215	AM / FM
2	26.975	AM / FM	22	27.225	AM / FM
3	26.985	AM / FM	23	27.255	AM / FM
4	27.005	AM / FM	24	27.235	AM / FM
5	27.015	AM / FM	25	27.245	AM / FM
6	27.025	AM / FM	26	27.265	AM / FM
7	27.035	AM / FM	27	27.275	AM / FM
8	27.055	AM / FM	28	27.285	AM / FM
9	27.065	AM / FM	29	27.295	AM / FM
10	27.075	AM / FM	30	27.305	AM / FM
11	27.085	AM / FM	31	27.315	AM / FM
12	27.105	AM / FM	32	27.325	AM / FM
13	27.115	AM / FM	33	27.335	AM / FM
14	27.125	AM / FM	34	27.345	AM / FM
15	27.135	AM / FM	35	27.355	AM / FM
16	27.155	AM / FM	36	27.365	AM / FM
17	27.165	AM / FM	37	27.375	AM / FM
18	27.175	AM / FM	38	27.385	AM / FM
19	27.185	AM / FM	39	27.395	AM / FM
20	27.205	AM / FM	40	27.405	AM / FM

Created by:

Approved by:

Rev.No:

For Stage:

Release Date:

Page: 29 Of 57



Model No: 3420

Model No:

Drawing No:

Customer :

H 520 PLUS

Rev. Date:

6. Frequencies for CE band (CEPT 40CH FM 4W)

CH	Frequency (MHz)	Modulation	CH	Frequency (MHz)	Modulation
1	26.965	FM	21	27.215	FM
2	26.975	FM	22	27.225	FM
3	26.985	FM	23	27.255	FM
4	27.005	FM	24	27.235	FM
5	27.015	FM	25	27.245	FM
6	27.025	FM	26	27.265	FM
7	27.035	FM	27	27.275	FM
8	27.055	FM	28	27.285	FM
9	27.065	FM	29	27.295	FM
10	27.075	FM	30	27.305	FM
11	27.085	FM	31	27.315	FM
12	27.105	FM	32	27.325	FM
13	27.115	FM	33	27.335	FM
14	27.125	FM	34	27.345	FM
15	27.135	FM	35	27.355	FM
16	27.155	FM	36	27.365	FM
17	27.165	FM	37	27.375	FM
18	27.175	FM	38	27.385	FM
19	27.185	FM	39	27.395	FM
20	27.205	FM	40	27.405	FM

Created by:

Approved by:

Rev.No:

For Stage:

Release Date:

Page: 30 Of 57



Model No: 3420

Model No:

Drawing No:

Customer :

H 520 PLUS

Rev. Date:

7. Frequencies for UK band (England 40CH FM 4W + CEPT 40CH FM 4W)

England Frequencies

CH	Frequency (MHz)	Modulation
1	27.60125	FM
2	27.61125	FM
3	27.62125	FM
4	27.63125	FM
5	27.64125	FM
6	27.65125	FM
7	27.66125	FM
8	27.67125	FM
9	27.68125	FM
10	27.69125	FM
11	27.70125	FM
12	27.71125	FM
13	27.72125	FM
14	27.73125	FM
15	27.74125	FM
16	27.75125	FM
17	27.76125	FM
18	27.77125	FM
19	27.78125	FM
20	27.79125	FM
21	27.80125	FM
22	27.81125	FM
23	27.82125	FM
24	27.83125	FM
25	27.84125	FM
26	27.85125	FM
27	27.86125	FM
28	27.87125	FM
29	27.88125	FM
30	27.89125	FM
31	27.90125	FM
32	27.91125	FM
33	27.92125	FM
34	27.93125	FM
35	27.94125	FM
36	27.95125	FM
37	27.96125	FM
38	27.97125	FM
39	27.98125	FM
40	27.99125	FM

CEPT Frequencies

CH	Frequency (MHz)	Modulation
1	26.965	FM
2	26.975	FM
3	26.985	FM
4	27.005	FM
5	27.015	FM
6	27.025	FM
7	27.035	FM
8	27.055	FM
9	27.065	FM
10	27.075	FM
11	27.085	FM
12	27.105	FM
13	27.115	FM
14	27.125	FM
15	27.135	FM
16	27.155	FM
17	27.165	FM
18	27.175	FM
19	27.185	FM
20	27.205	FM
21	27.215	FM
22	27.225	FM
23	27.255	FM
24	27.235	FM
25	27.245	FM
26	27.265	FM
27	27.275	FM
28	27.285	FM
29	27.295	FM
30	27.305	FM
31	27.315	FM
32	27.325	FM
33	27.335	FM
34	27.345	FM
35	27.355	FM
36	27.365	FM
37	27.375	FM
38	27.385	FM
39	27.395	FM
40	27.405	FM

Created by:

Approved by:

Rev.No:

For Stage:

Release Date:

Page: 31 Of 57



Model No: 3420

Model No:

Drawing No:

Customer :

H 520 PLUS

Rev. Date:

8. Frequencies for PL band (Poland 40CH AM / FM 4W Polish Frequencies – 5kHz)

CH	Frequency (MHz)	Modulation	CH	Frequency (MHz)	Modulation
1	26.960	AM / FM	21	27.210	AM / FM
2	26.970	AM / FM	22	27.220	AM / FM
3	26.980	AM / FM	23	27.250	AM / FM
4	27.000	AM / FM	24	27.230	AM / FM
5	27.010	AM / FM	25	27.240	AM / FM
6	27.020	AM / FM	26	27.260	AM / FM
7	27.030	AM / FM	27	27.270	AM / FM
8	27.050	AM / FM	28	27.280	AM / FM
9	27.060	AM / FM	29	27.290	AM / FM
10	27.070	AM / FM	30	27.300	AM / FM
11	27.080	AM / FM	31	27.310	AM / FM
12	27.100	AM / FM	32	27.320	AM / FM
13	27.110	AM / FM	33	27.330	AM / FM
14	27.120	AM / FM	34	27.340	AM / FM
15	27.130	AM / FM	35	27.350	AM / FM
16	27.150	AM / FM	36	27.360	AM / FM
17	27.160	AM / FM	37	27.370	AM / FM
18	27.170	AM / FM	38	27.380	AM / FM
19	27.180	AM / FM	39	27.390	AM / FM
20	27.200	AM / FM	40	27.400	AM / FM

Created by:

Approved by:

Rev.No:

For Stage:

Release Date:

Page: 32 Of 57



Model No: 3420

Model No:

Drawing No:

Customer :

H 520 PLUS

Rev. Date:

9. Frequencies for RU band (Russia 400CH AM / FM 4W)

CH	Freq.	CH	Freq.	CH	Freq.	CH	Freq.	CH	Freq.
1	25.615	81	26.515	161	27.415	241	28.315	321	29.215
2	25.625	82	26.525	162	27.425	242	28.325	322	29.225
3	25.635	83	26.535	163	27.435	243	28.335	323	29.235
4	25.655	84	26.555	164	27.455	244	28.355	324	29.255
5	25.665	85	26.565	165	27.465	245	28.365	325	29.265
6	25.675	86	26.575	166	27.475	246	28.375	326	29.275
7	25.685	87	26.585	167	27.485	247	28.385	327	29.285
8	25.705	88	26.605	168	27.505	248	28.405	328	29.305
9	25.715	89	26.615	169	27.515	249	28.415	329	29.315
10	25.725	90	26.625	170	27.525	250	28.425	330	29.325
11	25.735	91	26.635	171	27.535	251	28.435	331	29.335
12	25.755	92	26.655	172	27.555	252	28.455	332	29.355
13	25.765	93	26.665	173	27.565	253	28.465	333	29.365
14	25.775	94	26.675	174	27.575	254	28.475	334	29.375
15	25.785	95	26.685	175	27.585	255	28.485	335	29.385
16	25.805	96	26.705	176	27.605	256	28.505	336	29.405
17	25.815	97	26.715	177	27.615	257	28.515	337	29.415
18	25.825	98	26.725	178	27.625	258	28.525	338	29.425
19	25.835	99	26.735	179	27.635	259	28.535	339	29.435
20	25.855	100	26.755	180	27.655	260	28.555	340	29.455
21	25.865	101	26.765	181	27.665	261	28.565	341	29.465
22	25.875	102	26.775	182	27.675	262	28.575	342	29.475
23	25.905	103	26.805	183	27.705	263	28.605	343	29.505
24	25.885	104	26.785	184	27.685	264	28.585	344	29.485
25	25.895	105	26.795	185	27.695	265	28.595	345	29.495
26	25.915	106	26.815	186	27.715	266	28.615	346	29.515
27	25.925	107	26.825	187	27.725	267	28.625	347	29.525
28	25.935	108	26.835	188	27.735	268	28.635	348	29.535
29	25.945	109	26.845	189	27.745	269	28.645	349	29.545
30	25.955	110	26.855	190	27.755	270	28.655	350	29.555

Created by:

Approved by:

Rev.No:

For Stage:

Release Date:

Page: 33 Of 57



Model No: 3420

Model No:

Drawing No:

Customer :

H 520 PLUS

Rev. Date:

CH	Freq.	CH	Freq.	CH	Freq.	CH	Freq.	CH	Freq.
31	25.965	111	26.865	191	27.765	271	28.665	351	29.565
32	25.975	112	26.875	192	27.775	272	28.675	352	29.575
33	25.985	113	26.885	193	27.785	273	28.685	353	29.585
34	25.995	114	26.895	194	27.795	274	28.695	354	29.595
35	26.005	115	26.905	195	27.805	275	28.705	355	29.605
36	26.015	116	26.915	196	27.815	276	28.715	356	29.615
37	26.025	117	26.925	197	27.825	277	28.725	357	29.625
38	26.035	118	26.935	198	27.835	278	28.735	358	29.635
39	26.045	119	26.945	199	27.845	279	28.745	359	29.645
40	26.055	120	26.955	200	27.855	280	28.755	360	29.655
41	26.065	121	26.965	201	27.865	281	28.765	361	29.665
42	26.075	122	26.975	202	27.875	282	28.775	362	29.675
43	26.085	123	26.985	203	27.885	283	28.785	363	29.685
44	26.105	124	27.005	204	27.905	284	28.805	364	29.705
45	26.115	125	27.015	205	27.915	285	28.815	365	29.715
46	26.125	126	27.025	206	27.925	286	28.825	366	29.725
47	26.135	127	27.035	207	27.935	287	28.835	367	29.735
48	26.155	128	27.055	208	27.955	288	28.855	368	29.755
49	26.165	129	27.065	209	27.965	289	28.865	369	29.765
50	26.175	130	27.075	210	27.975	290	28.875	370	29.775
51	26.185	131	27.085	211	27.985	291	28.885	371	29.785
52	26.205	132	27.105	212	28.005	292	28.905	372	29.805
53	26.215	133	27.115	213	28.015	293	28.915	373	29.815
54	26.225	134	27.125	214	28.025	294	28.925	374	29.825
55	26.235	135	27.135	215	28.035	295	28.935	375	29.835
56	26.255	136	27.155	216	28.055	296	28.955	376	29.855
57	26.265	137	27.165	217	28.065	297	28.965	377	29.865
58	26.275	138	27.175	218	28.075	298	28.975	378	29.875
59	26.285	139	27.185	219	28.085	299	28.985	379	29.885
60	26.305	140	27.205	220	28.105	300	29.005	380	29.905

Created by:

Approved by:

Rev.No:

For Stage:

Release Date:

Page: 34 Of 57



Model No: 3420

Model No:

Drawing No:

Customer :

H 520 PLUS

Rev. Date:

CH	Freq.	CH	Freq.	CH	Freq.	CH	Freq.	CH	Freq.
61	26.315	141	27.215	221	28.115	301	29.015	381	29.915
62	26.325	142	27.225	222	28.125	302	29.025	382	29.925
63	26.355	143	27.255	223	28.155	303	29.055	383	29.955
64	26.335	144	27.235	224	28.135	304	29.035	384	29.935
65	26.345	145	27.245	225	28.145	305	29.045	385	29.945
66	26.365	146	27.265	226	28.165	306	29.065	386	29.965
67	26.375	147	27.275	227	28.175	307	29.075	387	29.975
68	26.385	148	27.285	228	28.185	308	29.085	388	29.985
69	26.395	149	27.295	229	28.195	309	28.095	389	29.995
70	26.405	150	27.305	230	28.205	310	29.105	390	30.005
71	26.415	151	27.315	231	28.215	311	29.115	391	30.015
72	26.425	152	27.325	232	28.225	312	29.125	392	30.025
73	26.435	153	27.335	233	28.235	313	29.135	393	30.035
74	26.445	154	27.345	234	28.245	314	29.145	394	30.045
75	26.455	155	27.355	235	28.255	315	29.155	395	30.055
76	26.465	156	27.365	236	28.265	316	29.165	396	30.065
77	26.475	157	27.375	237	28.275	317	29.175	397	30.075
78	26.485	158	27.385	238	28.285	318	29.185	398	30.085
79	26.495	159	27.395	239	28.295	319	29.195	399	30.095
80	26.505	160	27.405	240	28.305	320	29.205	400	30.105

Created by:

Approved by:

Rev.No:

For Stage:

Release Date:

Page: 35 Of 57



Model No: 3420

Model No:

Drawing No:

Customer :

H 520 PLUS

Rev. Date:

10. Frequencies for PO band (Poland 400CH AM / FM 4W Polish Frequencies -5kHz)

CH	Freq.	CH	Freq.	CH	Freq.	CH	Freq.	CH	Freq.
1	25.610	81	26.510	161	27.410	241	28.310	321	29.210
2	25.620	82	26.520	162	27.420	242	28.320	322	29.220
3	25.630	83	26.530	163	27.430	243	28.330	323	29.230
4	25.650	84	26.550	164	27.450	244	28.350	324	29.250
5	25.660	85	26.560	165	27.460	245	28.360	325	29.260
6	25.670	86	26.570	166	27.470	246	28.370	326	29.270
7	25.680	87	26.580	167	27.480	247	28.380	327	29.280
8	25.700	88	26.600	168	27.500	248	28.400	328	29.300
9	25.710	89	26.610	169	27.510	249	28.410	329	29.310
10	25.720	90	26.620	170	27.520	250	28.420	330	29.320
11	25.730	91	26.630	171	27.530	251	28.430	331	29.330
12	25.750	92	26.650	172	27.550	252	28.450	332	29.350
13	25.760	93	26.660	173	27.560	253	28.460	333	29.360
14	25.770	94	26.670	174	27.570	254	28.470	334	29.370
15	25.780	95	26.680	175	27.580	255	28.480	335	29.380
16	25.800	96	26.700	176	27.600	256	28.500	336	29.400
17	25.810	97	26.710	177	27.610	257	28.510	337	29.410
18	25.820	98	26.720	178	27.620	258	28.520	338	29.420
19	25.830	99	26.730	179	27.630	259	28.530	339	29.430
20	25.850	100	26.750	180	27.650	260	28.550	340	29.450
21	25.860	101	26.760	181	27.660	261	28.560	341	29.460
22	25.870	102	26.770	182	27.670	262	28.570	342	29.470
23	25.900	103	26.800	183	27.700	263	28.600	343	29.500
24	25.880	104	26.780	184	27.680	264	28.580	344	29.480
25	25.890	105	26.790	185	27.690	265	28.590	345	29.490
26	25.910	106	26.810	186	27.710	266	28.610	346	29.510
27	25.920	107	26.820	187	27.720	267	28.620	347	29.520
28	25.930	108	26.830	188	27.730	268	28.630	348	29.530
29	25.940	109	26.840	189	27.740	269	28.640	349	29.540
30	25.950	110	26.850	190	27.750	270	28.650	350	29.550

Created by:

Approved by:

Rev.No:

For Stage:

Release Date:

Page: 36 Of 57



Model No: 3420

Model No:

Drawing No:

Customer :

H 520 PLUS

Rev. Date:

CH	Freq.	CH	Freq.	CH	Freq.	CH	Freq.	CH	Freq.
31	25.960	111	26.860	191	27.760	271	28.660	351	29.560
32	25.970	112	26.870	192	27.770	272	28.670	352	29.570
33	25.980	113	26.880	193	27.780	273	28.680	353	29.580
34	25.990	114	26.890	194	27.790	274	28.690	354	29.590
35	26.000	115	26.900	195	27.800	275	28.700	355	29.600
36	26.010	116	26.910	196	27.810	276	28.710	356	29.610
37	26.020	117	26.920	197	27.820	277	28.720	357	29.620
38	26.030	118	26.930	198	27.830	278	28.730	358	29.630
39	26.040	119	26.940	199	27.840	279	28.740	359	29.640
40	26.050	120	26.950	200	27.850	280	28.750	360	29.650
41	26.060	121	26.960	201	27.860	281	28.760	361	29.660
42	26.070	122	26.970	202	27.870	282	28.770	362	29.670
43	26.080	123	26.980	203	27.880	283	28.780	363	29.680
44	26.100	124	27.000	204	27.900	284	28.800	364	29.700
45	26.110	125	27.010	205	27.910	285	28.810	365	29.710
46	26.120	126	27.020	206	27.920	286	28.820	366	29.720
47	26.130	127	27.030	207	27.930	287	28.830	367	29.730
48	26.150	128	27.050	208	27.950	288	28.850	368	29.750
49	26.160	129	27.060	209	27.960	289	28.860	369	29.760
50	26.170	130	27.070	210	27.970	290	28.870	370	29.770
51	26.180	131	27.080	211	27.980	291	28.880	371	29.780
52	26.200	132	27.100	212	28.000	292	28.900	372	29.800
53	26.210	133	27.110	213	28.010	293	28.910	373	29.810
54	26.220	134	27.120	214	28.020	294	28.920	374	29.820
55	26.230	135	27.130	215	28.030	295	28.930	375	29.830
56	26.250	136	27.150	216	28.050	296	28.950	376	29.850
57	26.260	137	27.160	217	28.060	297	28.960	377	29.860
58	26.270	138	27.170	218	28.070	298	28.970	378	29.870
59	26.280	139	27.180	219	28.080	299	28.980	379	29.880
60	26.300	140	27.200	220	28.100	300	29.000	380	29.900

Created by:

Approved by:

Rev.No:

For Stage:

Release Date:

Page: 37 Of 57



Model No: 3420

Model No:

Drawing No:

Customer :

H 520 PLUS

Rev. Date:

CH	Freq.	CH	Freq.	CH	Freq.	CH	Freq.	CH	Freq.
61	26.310	141	27.210	221	28.110	301	29.010	381	29.910
62	26.320	142	27.220	222	28.120	302	29.020	382	29.920
63	26.350	143	27.250	223	28.150	303	29.050	383	29.950
64	26.330	144	27.230	224	28.130	304	29.030	384	29.930
65	26.340	145	27.240	225	28.140	305	29.040	385	29.940
66	26.360	146	27.260	226	28.160	306	29.060	386	29.960
67	26.370	147	27.270	227	28.170	307	29.070	387	29.970
68	26.380	148	27.280	228	28.180	308	29.080	388	29.980
69	26.390	149	27.290	229	28.190	309	28.090	389	29.990
70	26.400	150	27.300	230	28.200	310	29.100	390	30.000
71	26.410	151	27.310	231	28.210	311	29.110	391	30.010
72	26.420	152	27.320	232	28.220	312	29.120	392	30.020
73	26.430	153	27.330	233	28.230	313	29.130	393	30.030
74	26.440	154	27.340	234	28.240	314	29.140	394	30.040
75	26.450	155	27.350	235	28.250	315	29.150	395	30.050
76	26.460	156	27.360	236	28.260	316	29.160	396	30.060
77	26.470	157	27.370	237	28.270	317	29.170	397	30.070
78	26.480	158	27.380	238	28.280	318	29.180	398	30.080
79	26.490	159	27.390	239	28.290	319	29.190	399	30.090
80	26.500	160	27.400	240	28.300	320	29.200	400	30.100

Created by:

Approved by:

Rev.No:

For Stage:

Release Date:

Page: 38 Of 57



Model No: 3420

Model No:

Drawing No:

Customer :

H 520 PLUS

Rev. Date:

11. Frequencies for PC band (Private Channels AM / FM 4W)

CH	Frequency (MHz)		CH	Frequency (MHz)	
1	25.645	AM / FM	26	27.895	AM / FM
2	25.695	AM / FM	27	27.945	AM / FM
3	25.745	AM / FM	28	27.995	AM / FM
4	25.795	AM / FM	29	28.045	AM / FM
5	25.845	AM / FM	30	28.095	AM / FM
6	26.095	AM / FM	31	28.345	AM / FM
7	26.145	AM / FM	32	28.395	AM / FM
8	26.195	AM / FM	33	28.445	AM / FM
9	26.245	AM / FM	34	28.495	AM / FM
10	26.295	AM / FM	35	28.545	AM / FM
11	26.545	AM / FM	36	28.795	AM / FM
12	26.595	AM / FM	37	28.845	AM / FM
13	26.645	AM / FM	38	28.895	AM / FM
14	26.695	AM / FM	39	28.945	AM / FM
15	26.745	AM / FM	40	28.995	AM / FM
16	26.995	AM / FM	41	29.245	AM / FM
17	27.045	AM / FM	42	29.295	AM / FM
18	27.095	AM / FM	43	29.345	AM / FM
19	27.145	AM / FM	44	29.395	AM / FM
20	27.195	AM / FM	45	29.445	AM / FM
21	27.445	AM / FM	46	29.695	AM / FM
22	27.495	AM / FM	47	29.745	AM / FM
23	27.545	AM / FM	48	29.795	AM / FM
24	27.595	AM / FM	49	29.845	AM / FM
25	27.645	AM / FM	50	29.895	AM / FM

Created by:

Approved by:

Rev.No:

For Stage:

Release Date:

Page: 39 Of 57

**Model No: 3420****Model No:****Drawing No:****Customer :****H 520 PLUS****Rev. Date:****Part list**

Code No	Name	Description	O'ty	Reference No
501-900019AB	53420EA(EXT ANT CAR ADAPT ASSY	H-520 PLUS	1	
911-110037GH	0301017Z(RES. FILM)	100 1/ 2W 5% ST MINI	1	SUB; R905A
911-610047BG	05B1024Z(RES. CHIP)	1K 1/16W 5% 1608	1	SMD; R901A
911-610067BG	05B1046Z(RES. CHIP)	100K 1/16W 5% 1608	1	SMD; R902A
911-633037BG	05B3314Z(RES. CHIP)	330 1/16W 5% 1608	1	SMD; R904A
911-647037BG	05B4717Z(RES. CHIP)	470 1/16W 5% 1608	1	SMD; R903A
915-124707CKAM	1047660Z(CAP. ELECT)	47UF 16V 20% 6X5	1	SUB; C903A
915-124708CKAE	1048139X(CAP. ELECT)	470UF 16V 20% 8X12 T3.5pt	1	SUB; C901A
913-421005CH	130B099Y(CAP. CERAMIC CHIP)	0.1UF GRM39X7R104K16V	1	SMD; C902A
913-428201HG	1382323Y(CAP. CERAMIC CHIP)	82PF GRM39COG820J50V	1	SMD; C907A
881-191042DL	TR	KTA1042 D/L	1	SMD; Q901A
881-191504SG	2020826(TR)	KTA1504ST1(G)(SOT-23)	1	SMD; Q902A
881-393875SG	2021120(TR)	KTC3875S(GR)SOT-23	1	SMD; Q903A
882-215232BS	2412630(DIODE ZENER)	1N5232BST	1	SUB; D902A
882-900001AA	2450153X(DIODE RECTIFIER)	1N4004	3	SUB; D901A.901B.901C
919-420051AA	3119729Z(COIL SPRING)	R4251-CS57-854392	1	SUB; L901A
925-990089AA	4229300(CONNECTOR SPRING)	GW9803302	3	SUB;
936-501005CB	EXT ANT DC CAR CORD	EXT ANT DC CAR CORD(H520 PLUS)	1	SUB;
501-400025AA	4A1219B (PCB ASSY)	180X155.6X1.2T	1	SMD;
932-557289AB	411289B (PCB ADAPTOR)	26.4X38.0X1.2T	1	SMD;
932-557994AB	411994B (PCB SUB)	14X20X1.2T	1	SMD;
501-400019AB	53420MPA(MAIN PCB AUTO ASSY)	H-520 PLUS	1	
911-600007BG	05B0005Z(RES. CHIP)	0 1/16W 5% 1608	1	SMD; L612
911-622037BG	05B2218Z(RES. CHIP)	220 1/16W 5% T 1608	1	SMD; R164
911-639047BG	05B3929Z(RES. CHIP)	3.9K 1/16W 5% 1608	1	SMD; R316
911-647047BG	05B4728Z(RES. CHIP)	4.7K 1/16W 5% 1608	1	SMD; R215
911-668047BG	05B6821Z(RES. CHIP)	6.8K 1/16W 5% 1608	2	SMD; R317.318
911-600007BF	05D0005Z(RES. CHIP)	0 1/16W 5% 1005	2	SMD; R114.605
911-610027BF	05D1002Z(RES. CHIP)	10 1/16W 5% 1005	2	SMD; R603.604
911-610037BF	05D1013Z(RES. CHIP)	100 1/16W 5% T 1005	9	SMD; R901.912.913.720.507.109.106.111.144
911-610047BF	05D1024Z(RES. CHIP)	1K 1/16W 5% T 1005	14	SMD; R704.727.103.113.319.320.321.322.214.307.305.117.701.146
911-610057BF	05D1035Z(RES. CHIP)	10K 1/16W 5% T 1005	17	SMD;R914.905.706.728.726.721.724.602.906.822.511.134 .118.213.824.147.120
911-610067BF	05D1046Z(RES. CHIP)	100K 1/16W 5% T 1005	10	SMD; R911.730.715.821.823.133.131.308.306.301
911-610077BF	05D1057Z(RES. CHIP)	1M 1/16W 5% T 1005	2	SMD; R139.142
911-610087BF	05D1068Z(CHIP RESISTOR)	10M 1/16W 5% T 1005	1	SMD; R129
911-612047BF	05D1222Z(RES. CHIP)	1.2K 1/16W 5% T 1005	1	SMD; R311
911-612057BF	05D1233Z(RES. CHIP)	12K 1/16W 5% 1005	2	SMD; R723.110
911-615037BF	05D1518Z(RES. CHIP)	150 1/16W 5% 1005	1	SMD; R135
911-615047BF	05D1529Z(RES. CHIP)	1.5K 1/16W 5% T 1005	4	SMD; R45.504.505.702
911-615057BF	05D1530Z(CHIP RESISTOR)	15K 1/16W 5% T 1005	2	SMD; R705.729
911-615067BF	05D1541Z(RES. CHIP)	150K 1/16W 5% 1005	1	SMD; R201
911-618057BF	05D1837Z(RES. CHIP)	18K 1/16W 5% T 1005	1	SMD; R501
911-618067BF	05D1848Z(RES. CHIP)	180K 1/16W 5% 1005	2	SMD; R736.809

Created by:**Approved by:****Rev.No:****For Stage:****Release Date:****Page: 40 Of 57**

**Model No: 3420****Model No:****Drawing No:****Customer :****H 520 PLUS****Rev. Date:****Part list**

Code No	Name	Description	O'ty	Reference No
911-622037BF	05D2218Z(RES. CHIP)	220 1/16W 5% 1005	3	SMD; R710.202.207
911-622047BF	05D2229Z(RES. CHIP)	2.2K 1/16W 5% T 1005	10	SMD; R732.601.121.304.712.145.807.703.731.136
911-622057BF	05D2230Z(RES. CHIP)	22K 1/16W 5% 1005	11	SMD; R906.132.124.125.126.127.122.734.902.105.735
911-622067BF	05D2241Z(RES. CHIP)	220K 1/16W 5% 1005	1	SMD; R811
911-633047BF	05D3325Z(RES. CHIP)	3.3K 1/16W 5% 1005	1	SMD; R143
911-633057BF	05D3336Z(RES. CHIP)	33K 1/16W 5% T 1005	3	SMD; R310.718.4
911-636057BF	05D3633Z(RES. CHIP)	36K 1/16W 5% 1005	1	SMD; R722
911-639047BF	05D3929Z(RES. CHIP)	3.9K 1/16W 5% 1005	1	SMD; R707
911-639057BF	05D3930Z(RES. CHIP)	39K 1/16W 5% 1005	3	SMD; R302.719.512
911-647027BF	05D4706Z(RES. CHIP)	47 1/16W 5% T 1005	5	SMD; R801.203.315.115.303
911-647037BF	05D4717Z(RES. CHIP)	470 1/16W 5% 1005	6	SMD; R815.816.506.107.108.817
911-647047BF	05D4728Z(RES. CHIP)	4.7K 1/16W 5% T 1005	9	SMD; R803.804.711.725.204.206.130.904.903
911-647057BF	05D4739Z(RES. CHIP)	47K 1/16W 5% T 1005	13	SMD; R812.813.814.802.805.806.717.714.104.716.6.502.733
911-647067BF	05D4740Z(RES. CHIP)	470K 1/16W 5% T 1005	4	SMD; R810.907.137.808
911-647077BF	05D4751Z(RES. CHIP)	4.7M 1/16W 5% 1005	1	SMD; R128
911-656037BF	05D5615Z(RES. CHIP)	560 1/16W 5% T 1005	2	SMD; R909.138
911-656057BF	05D5637Z(RES. CHIP)	56K 1/16W 5% 1005	4	SMD; R123.116.119.309
911-668037BF	05D6810Z(RES. CHIP)	680 1/16W 5% 1005	1	SMD; R908
911-668047BF	05D6821Z(RES. CHIP)	6.8K 1/16W 5% 1005	1	SMD ;R205
911-668067BF	05D6843Z(RES. CHIP)	680K 1/16W 5% 1005	2	SMD; R708.713
911-682047BF	05D8221Z(RES. CHIP)	8.2K 1/16W 5% 1005	6	SMD; R709.211.11.212.1.209
911-691057BF	05D9130Z(RES. CHIP)	91K 1/16W 5% 1005	2	SMD; R3.503
911-59002AA	0671045Y(RES. SEMIFIXED)	100K TMC3KJB100K 3DIA	2	SMD; RV102.201
917-99003AA	0751036(TRIMMER CHIP)	10K VG039NCHXT	3	SMD; RV701.103.702
917-99007AA	0754730(TRIMMER CHIP)	47K VG039NCHXT	2	SMD; RV501.101
884-190001AA	0971010(THERMISTOR CHIP)	100 NTCG163EH101J	2	SMD; TH102.101
913-411003HH	130B121Y(CAP. CERAMIC CHIP)	0.001UF GRM36X7R102K50V	4	SMD; C715.702.726.728
913-411004CH	130B165Y(CAP. CERAMIC CHIP)	0.01UF GRM36X7R103K16V	25	SMD; C706.914.911.141.142.226.218.213.208.207.502.516.205.203.137 .312.104.108.111.114.115.802.506.138.123
913-411005BH	130B363Y(CAP. CERAMIC CHIP)	0.1UF GRM36X5R104K10V	44	SMD; C912.913.915.804.805.1.720.719.725.803.806.608.607.809 .810.603.604.605.227.511.510.513.515.313.318.331.332.333.125. 154.119.129.121.122.130.134.133.135.124.714.143.247.246.701
913-412204EX	1302892Y(CAP. CERAMIC CHIP)	0.022UF GRM36Y5V223Z25V	1	SMD; C601
913-414703EH	1304471Y(CAP. CERAMIC CHIP)	0.0047UF GRM36X7R472K25V	2	SMD; C5.4
913-414704CH	1304525Y(CAP. CERAMIC CHIP)	0.047UF GRM36X5R473K10V	8	SMD; C722.505.210.225.151.136.704.707
913-425604CH	1305292(CAP. CERAMIC CHIP)	0.056UF GRM39X7R563K16V	1	SMD; C330
913-416803EH	1306299Y(CAP. CERAMIC CHIP)	0.0068UF GRM36X7R682K25V	1	SMD; C721
913-421002HG	1310939Y(CAP. CERAMIC CHIP)	100PF GRM39 COG101J 50V PT	8	SMD; C400.409.209.15.229.228.230.403
913-411001HC	1311277Y(CAP. CERAMIC CHIP)	10PF GRM36COG100D50V	2	SMD; C307.106
913-411002HG	1311299Y(CAP. CERAMIC CHIP)	100PF GRM36COG101J50V	8	SMD; C503.323.324.325.326.305.306.309
913-421006BX	1311354Y(CAP. CERAMIC CHIP)	1UF GRM39Y5V105Z10V	5	SMD; C903.908.909.910.905
913-421202HG	1312416Y(CAP. CERAMIC CHIP)	120PF GRM39COG121J50V	1	SMD; C233
913-411201HG	1312564Y(CAP. CERAMIC CHIP)	12PF GRM36COG120J50V	1	SMD; C105
913-411202HG	1312575Y(CAP. CERAMIC CHIP)	120PF GRM36COG121J50V	1	SMD; C131

Created by:**Approved by:****Rev.No:****For Stage:****Release Date:****Page: 41 Of 57**

**Model No: 3420****Model No:****Drawing No:****Customer :****H 520 PLUS****Rev. Date:****Part list**

Code No	Name	Description	O'ty	Reference No
913-411301HG	1313127Y(CAP. CERAMIC CHIP)	13PF GRM36COG130J50V	1	SMD; C315
913-411501HG	1315846Y(CAP. CERAMIC CHIP)	15PF GRM36 COG150J 50V	2	SMD; C304.204
913-421801HG	1318342Y(CAP. CERAMIC CHIP)	18PF GRM39COG180J50V	1	SMD; C242
913-421802HG	1318353Y(CAP. CERAMIC CHIP)	180PF GRM39COG181J50V	2	SMD; C232.221
913-411801HG	1318517Y(CAP. CERAMIC CHIP)	18PF GRM36COG180J50V	1	SMD; C113
913-412001HGAA	1320341Y(CAP. CERAMIC CHIP)	20PF GRM36COG200J50V	3	SMD; C320.807.808
913-422201HG	1322598Y(CAP.CERAMIC CHIP)	22PF GRM39 COG220J 50V PT	2	SMD; C216.235
913-422202HG	1322608Y(CAP. CERAMIC CHIP)	220PF GRM39COG221J 50V	2	SMD; C220.215
913-412201HGAA	1322870Y(CAP. CERAMIC CHIP)	22PF GRM36COG220J50V	1	SMD; C319
913-412202HGAA	1322881Y(CAP. CERAMIC CHIP)	220PF GRM36X7R221J50V	2	SMD; C3.301
913-422701HG	1327340Y(CAP. CERAMIC CHIP)	27PF GRM39 COG270J 50V PT	3	SMD; C103.234.241
913-422702HG	1327351Y(CAP. CERAMIC CHIP)	270PF GRM39COG271J50V	1	SMD; C236
913-412701HB	1327548Y(CAP. CERAMIC CHIP)	27PF GRM36COG270C50V	3	SMD; C316.206.201
913-413000HB	1331101Y(CAP. CERAMIC CHIP)	3PF GRM36COG030C50V	1	SMD; C314
913-423301HG	1333491Y(CAP. CERAMIC CHIP)	33PF GRM39COG330J50V	1	SMD; C402
913-423302HG	1333501Y(CAP. CERAMIC CHIP)	330PF GRM39COG331J50V	1	SMD; C223
913-413302HH	1333677Y(CAP. CERAMIC CHIP)	330PF GRM36X7R331K50V	1	SMD; C6
913-423901HG	1339305Y(CAP. CERAMIC CHIP)	39PF GRM39COG390J50V	1	SMD; C407
913-413901HG	1339429Y(CAP. CERAMIC CHIP)	39PF GRM36COG390J50V	2	SMD; C302.127
913-424000HB	1340121Y(CAP. CERAMIC CHIP)	4PF GRM39COG040C50V	1	SMD; C224
913-414000HBAA	1340187Y(CAP. CERAMIC CHIP)	4PF GRM36COG040C50V	1	SMD; C126
913-424701HG	1347571Y(CAP. CERAMIC CHIP)	47PF GRM39COG470J50V	5	SMD; C139.244.243.405.406
913-424702HG	1347724Y(CAP. CERAMIC CHIP)	470PF GRM39COG471J50V	1	SMD; C101
913-414701HG	1347791Y(CAP. CERAMIC CHIP)	47PF GRM36COG470J50V	2	SMD; C716.709
913-415000HB	1350236Y(CAP. CERAMIC CHIP)	5PF GRM36COG050C50V	1	SMD; C308
913-425101HG	1351079Y(CAP. CERAMIC CHIP)	51PF GRM39COG510J50V	2	SMD; C404.408
913-416000HC	1360187Y(CAP. CERAMIC CHIP)	6PF GRM36COG060D50V	1	SMD; C303
913-426801HG	1368392Y(CAP. CERAMIC CHIP)	68PF GRM39COG680J50V	1	SMD; C240
913-426802HH	1368402Y(CAP. CERAMIC CHIP)	680PF GRM39X7R681K50V	1	SMD; C214
913-416801HG	1368600Y(CAP. CERAMIC CHIP)	68PF GRM36COG680J50V	2	SMD; C10.128
913-418202HH	1382467Y(CAP.CERAMIC CHIP)	820PF GRM36X7R821K 50V	1	SMD; C724
913-428202HG	1382490Y(CAP. CERAMIC CHIP)	820PF GRM39C0G821J50V	1	SMD; C219
915-611005FKLB	1401143Z(CAP TANTALUM CHIP)	0.1UF 35V A 20%	1	SMD; C329
915-611006CKLCA	1410361Z (CAP. TANTALUM CHIP)	1UF 293D105X0016A2T 16V	9	SMD; C710.713.708.717.718.328.109.110.711
915-611007AKLC	1410592(CAP TANTALUM CHIP)	10UF 6.3V A 20%	14	SMD; C907.901.904.705.801.602.514.327.311.317.132.117.118.512
915-611008ZC	1410676Z(CAP TANTALUM CHIP)	100UF 16V D 20%	1	SMD; C606
915-612206ZA	1422272Z(CHIP TANTALUM)	2.2UF 16V A 20%	2	SMD; C906.902
915-612207CK	1422912(CHIP TANTALUM)	22UF 16V B 20%	2	SMD; C2.153
915-614707	1447298Z(CAP TANTALUM CHIP)	47UF 16V D 20%	1	SMD; C727
917-152001AA	1720211Y(TRIMMER CHIP)	20PF STC3M20-TA	1	SMD; CT1
881-190226SA	2000828(TR)	KRA226S(SOT-23)	1	SMD; Q601
881-893078AA	2002709Z(TR FET)	2SK3078A	1	SMD; Q203

Created by:**Approved by:****Rev.No:****For Stage:****Release Date:****Page: 42 Of 57**

**Model No: 3420****Model No:****Drawing No:****Customer :****H 520 PLUS****Rev. Date:****Part list**

Code No	Name	Description	O'ty	Reference No
881-883476AA	2003014(TR FET)	2SK3476	1	SMD; Q204
881-191504SG	2020826(TR)	KTA1504ST1(G)(SOT-23)	3	SMD; Q707.502.506
881-390101SN	2020859(TR)	KRC101SNA, NPN, SOT-23	9	SMD; Q705.304.305.306.307.111.104.105.2
881-190110SP	2020925(TR)	KRA110SPK	1	SMD; Q109
881-390104SN	2020958Z(TR)	KRC104SND(SOT-23)	11	SMD; Q902.904.703.702.803.602.508.504.507.1.802
881-393875SG	2021120(TR)	KTC3875S(GR)SOT-23	12	SMD; Q701.901.903.706.112.509.510.505.110.308.106.108
881-393880SY	2021537(TR)	KTC3880SY(SOT-23)	6	SMD; Q202.201.302.303.301.101
881-190105SP	2021559(TR)	KRA105S(SOT-23)	1	SMD; Q801
881-990211GR	2021834(TR FET)	KTK211GR	2	SMD; Q102.103
874-102630FA	2214605(IC PLL(DUAL))	BU2630F	1	SMD; IC302
875-905020SP	2217178(IC COMPANDER)	DBL5020V (SOP)	1	SMD; IC901
875-910931VT	2218831(IC AM/FM DETECTOR)	TK10931VTL	1	SMD; IC101
875-100324FL	2220185A(IC OP AMP)	KIA324F-EL	2	SMD; IC4.102
875-907042SO	2220239A(IC VOLT. DETECTOR)	KIA7042AF	1	SMD; IC803
881-191042DL	TR	KTA1042 D/L	1	SMD; Q501
875-301117SO	IC REGULATOR	LD1117L-5.0V-A(SOT-223)	1	SMD; IC501
874-114066BD	2232249(IC)	MC14066BDR2G	1	SMD; IC902
876-900001AA	2218051(IC E2PROM)	24LC16A(SOP-8)	1	SMD; IC802
874-178569AL	2218858 (IC OTP)	EM78P569ALQJ	1	SMD; IC801
875-100386SP	2310381(IC)	LM386MX-1 (SO-08)	1	SMD; IC601
882-590251SA	2420246(DIODE)	KDV251S	2	SMD; D302.301
882-190226AA	2430494(DIODE SWITCHING)	KDS226	5	SMD; D701.801.802.803.101
882-190184SA	2430515(DIODE SWITCHING)	KDS184S	14	SMD; D706.708.705.703.704.804.202.110.107.108.109.111.502.702
882-990114AA	2430801Z(DIODE)	KDS114	4	SMD; D203.303.102.103
883-193010SG	2512907(LED LAMP CHIP)	KPA-3010SGC	6	SMD; LED1.3.4.5.6.7
928-290455KC	2703587(DISCRIMINATOR)	CDBC455KCAY24-R0	1	SMD; T104
919-921220YA	3120556(COIL CHIP)	2.2UH MLF1608A2R2KT	5	SMD; L202.302.201.R210.208
919-921100AB	3121322(COIL INDUCTOR CHIP)	1UH SWI0805FT1R0	2	SMD; L16.404
919-921270ZA	3121706(COIL INDUCTOR CHIP)	270NH SWI0805CTR27	3	SMD; L401.402.403
919-210027AA	COIL IFT SMD	D6-0363A(27MHZ)	2	SMD; T204.203
919-210028AA	COIL IFT SMD	3210949(28MHZ)	1	SMD; T102
919-210107AA	COIL IFT SMD	3210334(10.7MHZ)	1	SMD; T103
919-210796AA	COIL IFT SMD	3201276(7.96MHZ)	1	SMD; T302
501-400019BC	4A1217D(PCB ASSY)	145.4X118.0X1.2T	1	SMD;
932-502102BB	411286C P.C.B JACK	19.6 X 24.0 X 1.2T	1	SMD;
932-502102CB	411295C (P.C.B PTT)	12.0 X 14.5 X 1.2T	1	SMD;
932-502102AC	411416D(PCB MAIN)	50X123.8X1.2T	1	SMD;
501-500019AC	53420UPA(UPPER COVER ASSY)	H-520 PLUS	1	
927-140004ZA	4201206Z(SPEAKER)	36-8B-52F2 8 OHM	1	SUB;SP1
501-400019AC	53420MPM(MAIN PCB MANUAL ASSY)	H-520 PLUS	1	
911-168027GH	0306803Z(RES. FILM)	68 1/ 2W 5% ST MINI	1	SUB; R513
915-123307CKAC	1033139Y(CAP. ELECT)	33UF 16V 20% 5X11 T2.5pt	1	SUB; C507

Created by:**Approved by:****Rev.No:****For Stage:****Release Date:****Page: 43 Of 57**

**Model No: 3420****Model No:****Drawing No:****Customer :****H 520 PLUS****Rev. Date:****Part list**

Code No	Name	Description	O'ty	Reference No
915-124707CKAM	1047660Z(CAP. ELECT)	47UF 16V 20% 6X5	1	SUB; C609
915-124708CKAE	1048139X(CAP. ELECT)	470UF 16V 20% 8X12 T3.5pt	1	SUB; C509
913-113902HH	1339042(CAP. CERAMIC DISK)	390PF SL391K 50V	1	SUB; C239
882-900001AA	2450153X(DIODE RECTIFIER)	1N4004	2	SUB; D501.503
922-390001AE	FLAT CABLE CONNECTOR 6P	6P 70MM 5PSAN/6P 1.25MM	1	SUB;
934-590100AA	LCD DISPLAY(H520 PLUS)	912-841A-0100	1	SUB; LCD1
928-130017AA	CRYSTAL RESONATOR	FTX4.5M16S-30/30	1	SUB; X302
928-130001BA	2604855V(CRYSTAL HC49U)	10.240MHZ -30 30PM 32P	1	SUB; X101
928-130001AW	2634855(CRYSTAL OSCILLATOR)	32.768KHZ -10 20PPM 12.5PF	1	SUB; X801
929-310455HTZA	2703301Z(FILTER CERAMIC)	LTM455HTU	1	SUB; CF102
929-300049TA	2710305Z(FILTER CRYSTAL)	HC49/T (10.695M)	1	SUB; CF101
927-130007AA	4202741Y(MIC CONDENSER)	F9745AP362-34	1	SUB; MIC1
925-140006AA	SOCKET	6P HEADER (SMD)	1	SUB;
925-730003AA	4208062U(JACK STEREO EARPHONE)	EJS-4-4035S	1	SUB; JACK1
925-730004AA	4208073V(JACK STEREO EARPHONE)	EJS-4-4125S	1	SUB; JACK2
925-990090AA	WAFER	2.0MM 2P	1	SUB;
924-251202AA	4312310Y(SW SLIDE)	SSA-12D02-G2-TA	1	SUB; SW501
924-160010AB	4360300(SW TACT)	SKHUPFE010	1	SUB; SW4
924-430901AA	4504364Y(VR)	RD901SF-20-15K-A10K	2	SUB; VR601.102
501-394001BS	MOLEX PLUG 2P ASSY	2P 120MM 2PSCN/2PXH 24#2.0MM	1	SUB;
937-901001AF	509110Z(COIL SPRING)	0.55X3.4RX6.5T	1	SUB; L211
919-490030AA	COIL SPRING	0.4X3.5LX7T SMD	1	SMD; L206
919-490030AB	COIL SPRING	0.4X3.5LX8T SMD	1	SMD; L204
919-490030AC	COIL SPRING	0.4X3.5LX9T SMD	6	SMD; L203.205.207.208.209.210
936-501001AB	CONNECTOR WIRE	UL1007AWG24CSA 2PIN 80/120MM(H520 PLUS)	1	SUB;
936-501002AB	CONNECTOR WIRE	UL1571AWG24CSA 6PIN 70MM(H520 PLUS)	1	SUB;
925-990002ZA	4210368A(CONNECTOR PLUG)	UG-1094/U(W)	1	SUB;CON4
931-470002AA	WHIP ANTENA	HSMX-520-UWB	1	SUB;
937-351200AA	ADAPTOR	AV35-120-020T(DC12V,200mA)	1	SUB;
923-111102AF	4271925(WIRE)	VINYLO80D(7/0.12)YEL	0.06	SUB;SPK+
923-111102AG	4271936(WIRE)	VINYLO80D(7/0.12)GRN	0.05	SUB;SPK-
922-690001AA	COAXIAL CABLE (H-520 PLUS)	RG178 5-10-108MM	0.15	SUB;

Created by:**Approved by:****Rev.No:****For Stage:****Release Date:****Page: 44 Of 57**



Model No: 3420

Model No:

Drawing No:

Customer :

H 520 PLUS

Rev. Date:

VOLTAGE CHART

TRANSISTOR

Ref.	PIN	TX	RX	Ref.	PIN	TX	RX
Q601	E	8.42	8.65	Q2	E	0.04	0
KRA226	C	1.55	8.64	KRC101	C	0.04	0
	B	8.37	0.08		B	0.04	4.21
Q203	G	2.5	0.08	Q109	E	0.04	4.21
2SK3078	D	2.32	2.95	KRA110	C	0.06	4.16
	S	0.04	0		B	4.77	0.02
Q204	G	2.48	0.08	Q902	E	0.05	0
2SK3476	D	2.27	2.95	KRC104	C	0.08	0.02
	S	0.04	0		B	4.77	4.72
Q707	E	4.52	4.5	Q904	E	0.05	0
KTA1504	C	0	0.13	KRC104	C	0.08	0.02
	B	5.25	5.29		B	4.76	4.63
Q502	E	7.85	8.22	Q703	E	0.05	0
KTA1504	C	2.29	2.96	KRC104	C	0.06	0
	B	7.29	7.71		B	4.71	4.66
Q506	E	5.06	4.98	Q702	E	0.04	0
KTA1504	C	4.95	0.15	KRC104	C	0.44	1.65
	B	4.28	4.9		B	0.04	0
Q705	E	0.03	0	Q803	E	0.03	0
KRC101	C	1.27	1.24	KRC104	C	7.02	7.17
	B	0.01	0		B	0.04	0
Q304	E	0.03	0	Q602	E	0.04	0
KRC101	C	0.04	0.38	KRC104	C	8.36	0.08
	B	4.3	0.46		B	0.03	4.63
Q305	E	0.04	0	Q508	E	0.04	0
KRC101	C	0.43	0.38	KRC104	C	0.03	3.17
	B	0.49	0.46		B	4.24	0
Q306	E	0.03	0	Q504	E	0.04	0
KRC101	C	0.04	0	KRC104	C	0.03	3.19
	B	3.77	3.73		B	4.24	0
Q307	E	0.03	0	Q507	E	0.04	0
KRC101	C	0.46	0.48	KRC104	C	0.13	4.9
	B	0.42	0.4		B	4.76	0
Q111	E	0.04	0	Q1	E	0.04	0
KRC101	C	0.22	0.2	KRC104	C	0.04	1.38
	B	0.49	0.45		B	4.24	0

Created by:

Approved by:

Rev.No:

For Stage:

Release Date:

Page: 45 Of 57



Model No: 3420
Customer :

Model No:
H 520 PLUS

Drawing No:
Rev. Date:

TRANSISTOR

Ref.	PIN	TX	RX	Ref.	PIN	TX	RX
Q901	E	1.12	1.07	Q303	E	0.03	0
KTC3875	C	4.15	4.1	KTC3880	C	2.33	2.3
	B	1.6	1.68		B	0.74	0.71
Q903	E	0.89	0.83	Q301	E	3.19	3.17
KTC3875	C	4.21	4.15	KTC3880	C	4.27	4.24
	B	1.54	1.5		B	3.84	3.82
Q706	E	2.05	2.66	Q101	E	0.05	1.78
KTC3875	C	4.85	4.85	KTC3880	C	0.06	3.98
	B	1.95	2.79		B	0.04	0.72
Q112	E	0.05	0.08	Q801	E	5.04	4.98
KTC3875	C	0.06	1.71	KRA105	C	0.04	0
	B	0.04	0.69		B	5.01	4.96
Q509	E	2.29	2.95	Q102	G	0.04	0
KTC3875	C	7.37	7.73	KTK211	D	0.02	3.39
	B	2.77	3.2		S	0.02	0.86
Q510	E	0.04	0	Q103	G	0.04	0
KTC3875	C	0.04	0	KTK211	D	0.02	3.4
	B	0.71	0.67		S	0.02	0.87
Q505	E	0.04	4.2	Q501	E	8.49	8.65
KTC3875	C	5.03	4.98	KTA1042	C	2.27	2.91
	B	0.13	4.9		B	7.93	8.2
Q110	E	0.07	0	Q108	E	0.05	0
KTC3875	C	0.08	0.01	KTC3875	C	0.06	3.38
	B	0.87	0.51		B	0.05	0
Q308	E	4.34	4.3	Q202	E	1.25	0
KTC3875	C	5.02	4.98	KTC3880	C	4.94	0.15
	B	5	4.96		B	1.87	0.06
Q106	E	0.04	0	Q201	E	0.68	0
KTC3875	C	0	0	KTC3880	C	4.8	0.15
	B	0.04	0.63		B	1.35	0.15
Q104	E	0.04	0	Q802	E	0.04	0
KRC101	C	0.23	0.2	KRC104	C	0.04	4.71
	B	0.49	0.45		B	0.04	0
Q105	E	0.04	0	Q701	E	0.04	0
KRC101	C	0.04	0	KTC3875	C	0.04	0
	B	3.78	3.73		B	0.04	0.72
Q302	E	0.03	0				
KTC3880	C	2.28	3.19				
	B	0.74	0				

Created by:

Approved by:

Rev.No:

For Stage:

Release Date:

Page: 46 Of 57



Model No: 3420
Customer :

Model No:
H 520 PLUS

Drawing No:
Rev. Date:

DIODE

Ref.	PIN	TX	RX	Ref.	PIN	TX	RX
D302 KDV251	A _{1/2} K	0.03/0.00 0.03	0.00/0.00 0	D502 KDS184	A _{1/2} K	3.19/2.29 2.76	3.64/2.93 3.19
D301 KDV251	A _{1/2} K	0.03/0.00 0.04	0.00/0.00 4.72	D702 KDS184	A _{1/2} K	-3.5 0.04	0.09/1.36 0.72
D109 KDS184	A _{1/2} K	0.1818182 0.04	1.21/0.07 0.63	D203 KDS114	A K	0.04 2.24	0 0
D803 KDS226	A _{1/2} K	-0.9375 0.04	1.3076923 0	D303 KDS114	A K	0.04 0.03	0.72 0
D111 KDS184	A _{1/2} K	0.05/0.05 0.04	3.39/0.00 2.93	D102 KDS114	A K	0.05 0.04	4.1 3.4
D701 KDS226	A _{1/2} K	0.04/0.06 0.05	0.00/0.02 0.01	D103 KDS114	A K	0.05 0.04	4.1 3.39
D801 KDS226	A _{1/2} K	0.12/4.25 4.75	#DIV/0! 0	D107 KDS184	A _{1/2} K	0.00/0.11 0.84	1.20/0.11 0.63
D802 KDS226	A _{1/2} K	-2 0	#DIV/0! 0	D108 KDS184	A _{1/2} K	0.00/-0.18 0.11	0.00/-0.20 0.07
D101 KDS226	A _{1/2} K	0.04/0.04 0.04	0.00/0.00 0	D704 KDS184	A _{1/2} K	0.04/1.27 0.88	0.03/1.24 0.85
D706 KDS184	A _{1/2} K	5.25/0.30 4.8	5.29/0.26 4.83	D804 KDS184	A _{1/2} K	0.05/1.20 0.87	0.00/1.18 0.84
D708 KDS184	A _{1/2} K	1.95/1.42 1.43	2.80/0.14 2.29	D202 KDS184	A _{1/2} K	1.61/-0.08 0.84	0.15/-0.21 0.5
D705 KDS184	A _{1/2} K	0.25/5.02 4.51	0.25/4.98 4.48	D110 KDS184	A _{1/2} K	1.55/0.90 4.22	1.50/0.83 4.15
D703 KDS184	A _{1/2} K	0.09/1.29 0.89	0.08/1.25 0.85	D501 1N4004	A K	8.6 0.03	8.67 0
D503 1N4004	A K	0.03 0.4	0 0.38				

Created by:

Approved by:

Rev.No:

For Stage:

Release Date:

Page: 47 Of 57

IC

Ref.	PIN	TX	RX	PIN	TX	RX
IC801 CPU	1	0.00	0.00	51	4.76	4.73
	2	0.00	0.00	52	0.04	4.76
	3	0.00	0.00	53	0.04	0.00
	4	0.00	0.00	54	0.04	0.00
	5	0.00	0.00	55	4.75	0.00
	6	0.00	0.00	56	4.65	4.63
	7	0.00	0.00	57	4.65	4.63
	8	0.00	0.00	58	4.65	4.63
	9	0.00	0.00	59	4.65	4.63
	10	2.77	2.72	60	0.04	0.00
	11	2.75	2.72	61	0.04	0.00
	12	2.75	2.72	62	4.76	4.74
	13	2.75	2.72	63	0.04	0.00
	14	2.75	2.72	64	0.05	0.01
	15	0.00	0.00	65	0.05	0.01
	16	0.00	0.00	66	0.10	0.06
	17	0.00	0.00	67	2.74	2.72
	18	0.00	0.00	68	2.74	2.72
	19	0.00	0.00	69	2.75	2.72
	20	0.00	0.00	70	2.74	2.71
	21	4.76	4.74	71	2.76	2.73
	22	0.00	0.00	72	2.74	2.72
	23	0.00	0.00	73	2.75	2.73
	24	0.00	0.00	74	2.77	2.74
	25	0.00	0.00	75	2.76	2.74

Created by:**Approved by:****Rev.No:****For Stage:****Release Date:****Page: 48 Of 57**



Model No: 3420

Model No:

Drawing No:

Customer :

H 520 PLUS

Rev. Date:

IC

Ref.	PIN	TX	RX	PIN	TX	RX
IC801 CPU	26	0.00	0.00	76	0.00	0.00
	27	0.00	0.00	77	0.00	0.00
	28	0.00	0.00	78	0.00	0.00
	29	1.25	1.22	79	0.00	0.00
	30	0.04	0.00	80	0.00	0.00
	31	0.04	0.00	81	2.75	2.72
	32	0.04	0.00	82	2.75	2.72
	33	0.04	0.00	83	2.75	2.72
	34	4.69	4.66	84	2.77	2.74
	35	0.04	0.00	85	2.75	2.72
	36	0.06	0.02	86	2.77	2.74
	37	0.84	0.83	87	2.76	2.74
	38	0.68	0.87	88	2.75	2.72
	39	4.75	4.72	89	2.76	2.73
	40	4.75	4.72	90	2.75	2.72
	41	4.74	4.72	91	2.76	2.73
	42	2.29	2.26	92	2.76	2.73
	43	2.29	2.26	93	2.75	2.72
	44	0.03	0.00	94	2.75	2.72
	45	0.10	0.07	95	2.78	2.75
	46	0.04	4.73	96	2.77	2.74
	47	4.75	0.00	97	2.76	2.73
	48	0.03	4.72	98	2.75	2.72
	49	4.76	0.02	99	2.76	2.74
	50	4.75	4.73	100	2.76	2.74

Created by:

Approved by:

Rev.No:

For Stage:

Release Date:

Page: 49 Of 57

IC

Ref.	PIN	TX	RX	PIN	TX	RX
IC102 KIA324	1	0.04	2.92	8	0.00	1.19
	2	0.11	0.28	9	0.00	1.19
	3	0.11	0.29	10	0.04	1.19
	4	0.05	4.18	11	0.04	0.00
	5	0.11	0.31	12	0.04	0.01
	6	0.12	0.30	13	0.04	1.19
	7	0.07	2.96	14	0.00	0.00
IC901 DBL5020	1	1.36	1.30	8	2.39	2.34
	2	1.37	1.33	9	2.39	2.34
	3	0.50	0.79	10	2.39	2.34
	4	2.40	2.34	11	2.39	2.34
	5	2.40	2.34	12	0.61	0.53
	6	3.08	3.03	13	1.38	1.33
	7	0.05	0.00	14	4.71	4.65
IC802 24LC16	1	0.05	0.00	5	0.11	0.06
	2	0.05	0.00	6	0.11	0.06
	3	0.05	0.00	7	0.08	0.03
	4	0.05	0.00	8	4.73	4.69
IC902 14066	1	0.00	0.18	8	0.03	0.00
	2	0.00	0.04	9	0.00	0.00
	3	0.00	0.02	10	0.00	0.00
	4	0.00	0.04	11	0.00	0.00
	5	4.69	4.63	12	4.68	4.62
	6	0.08	0.02	13	0.05	0.02
	7	0.05	0.00	14	5.04	4.98
IC601 LM386	1	1.01	1.29	5	1.08	4.27
	2	0.08	0.00	6	1.15	8.60
	3	0.08	0.00	7	1.11	4.32
	4	0.08	0.00	8	1.11	1.23

Model No: 3420

Model No:

Drawing No:

Customer :

H 520 PLUS

Rev. Date:

IC

Ref.	PIN	TX	RX	PIN	TX	RX
IC302 BU2630	1	2.08	2.07	9	0.11	0.06
	2	0.04	0.00	10	0.11	0.09
	3	0.04	0.00	11	2.41	2.41
	4	0.49	0.45	12	3.78	3.73
	5	4.31	0.46	13	0.50	0.45
	6	0.04	0.00	14	1.11	0.94
	7	0.05	0.01	15	4.94	4.89
	8	0.05	0.01	16	2.14	2.09
IC101 TK10931	1	0.05	3.88	13	0.34	1.50
	2	0.05	3.36	14	0.05	2.92
	3	0.04	2.57	15	0.04	1.16
	4	0.06	3.93	16	0.04	0.00
	5	0.02	1.82	17	0.04	1.59
	6	0.00	1.17	18	0.34	1.50
	7	0.00	2.96	19	0.06	1.82
	8	0.00	2.96	20	0.04	3.14
	9	0.00	2.96	21	0.04	3.86
	10	0.04	3.00	22	0.03	0.00
	11	0.05	3.88	23	0.04	0.00
	12	0.00	2.23	24	0.04	0.98
IC4 KIA324	1	1.96	1.91	8	2.03	1.99
	2	1.97	1.93	9	2.05	2.01
	3	1.97	1.93	10	2.05	2.01
	4	4.90	4.86	11	0.04	0.00
	5	0.35	0.34	12	2.34	2.30
	6	0.32	0.31	13	2.35	2.31
	7	3.69	3.64	14	2.36	2.31

Created by:

Approved by:

Rev.No:

For Stage:

Release Date:

Page: 51 Of 57



Model No: 3420

Model No:

Drawing No:

Customer :

H 520 PLUS

Rev. Date:

IC

Ref.	PIN	TX	RX
IC501 LD1117	1	0.05	0.00
	2	5.03	4.98
	3	8.43	8.63
IC803 KIA7402	1	5.03	4.98
	2	0.04	0.00
	3	4.76	4.73

Created by:

Approved by:

Rev.No:

For Stage:

Release Date:

Page: 52 Of 57

SEMICONDUCTOR LEAD IDENTIFICATION AND IC INTERNAL CONNECTIONS

DIODES

1N4004 .1N4148
.1N5232
1N5404 .1N5237 .

KDV251

KDS184

KDS114

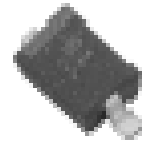
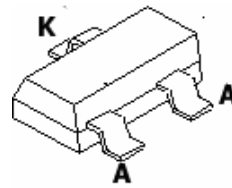
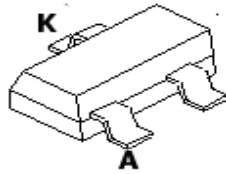
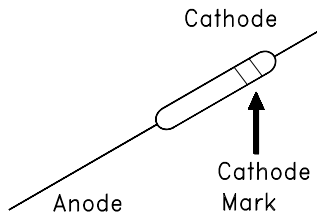

Model No: 3420

Model No:

Drawing No:

Customer :

H 520 PLUS

Rev. Date:

TRANSISTORS / FET

KTK211

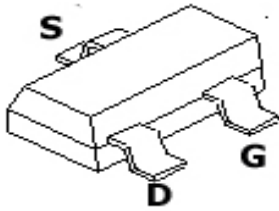

KRC101S, KRC110,
KTC3876, KTC3880
KTC3875,3880 KRC101~104

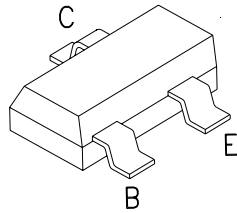

Q204: 2SK3476

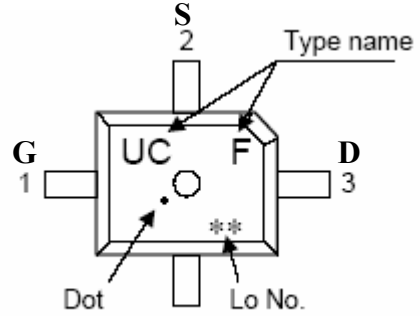

IC501 : LD111750

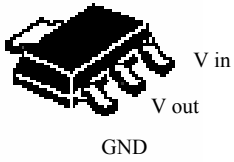

Q203: 2SK3078



Q501 : KTA1042

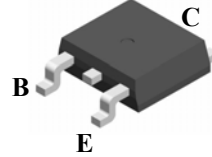

Created by:

Approved by:

Rev.No:

For Stage:

Release Date:

Page: 54 Of 57

Model No: 3420
Customer :

Model No: H 520 PLUS

Drawing No:
Rev. Date:

INTERATED CIRCUITS

IC801: EM78P569

NC	1	80	NC
NC	2	79	NC
NC	3	78	NC
NC	4	77	NC
NC	5	76	NC
NC	6	75	SE021 PB7
NC	7	74	SE022 PB6
NC	8	73	SE023 PB5
NC	9	72	SE024 PB4
SE09	10	71	SE025 PB3
COM3	11	70	SE026 PB2
COM2	12	69	SE027 PB1
COM1	13	68	SE028 PB0
COM0	14	67	SE029 PC7
NC	15	66	SE030 PC6
NC	16	65	SE031 PC5
NC	17	64	PC4
NC	18	63	PC3
NC	19	62	PC2
NC	20	61	PC1
AVDD	21	60	PC0
NC	22	59	INT0 P70
NC	23	58	INT1 P71
NC	24	57	INT2 P72
NC	25	56	INT3 P73
NC	26	55	SD0 P74
NC	27	54	SD1 P75
NC	28	53	SC0 P76
PULL	29	52	P77
AVSS	30	51	VDD

IC 302: BU2630F

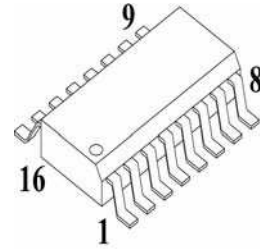

IC102/ 4 : KIA324
IC901: DBL5020
IC902 : 14066

IC101 : TK10931

IC802: 24LLC16 / 8 PIN
IC601 : LM386

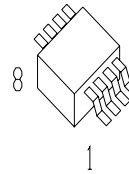
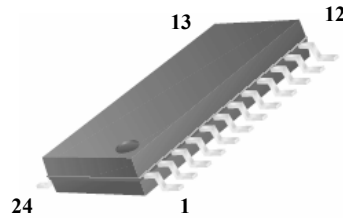
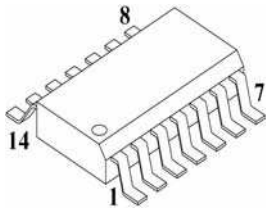

Created by:
For Stage:

Approved by:
Release Date:

Rev.No:
Page: 55 Of 57

Explode view drawing

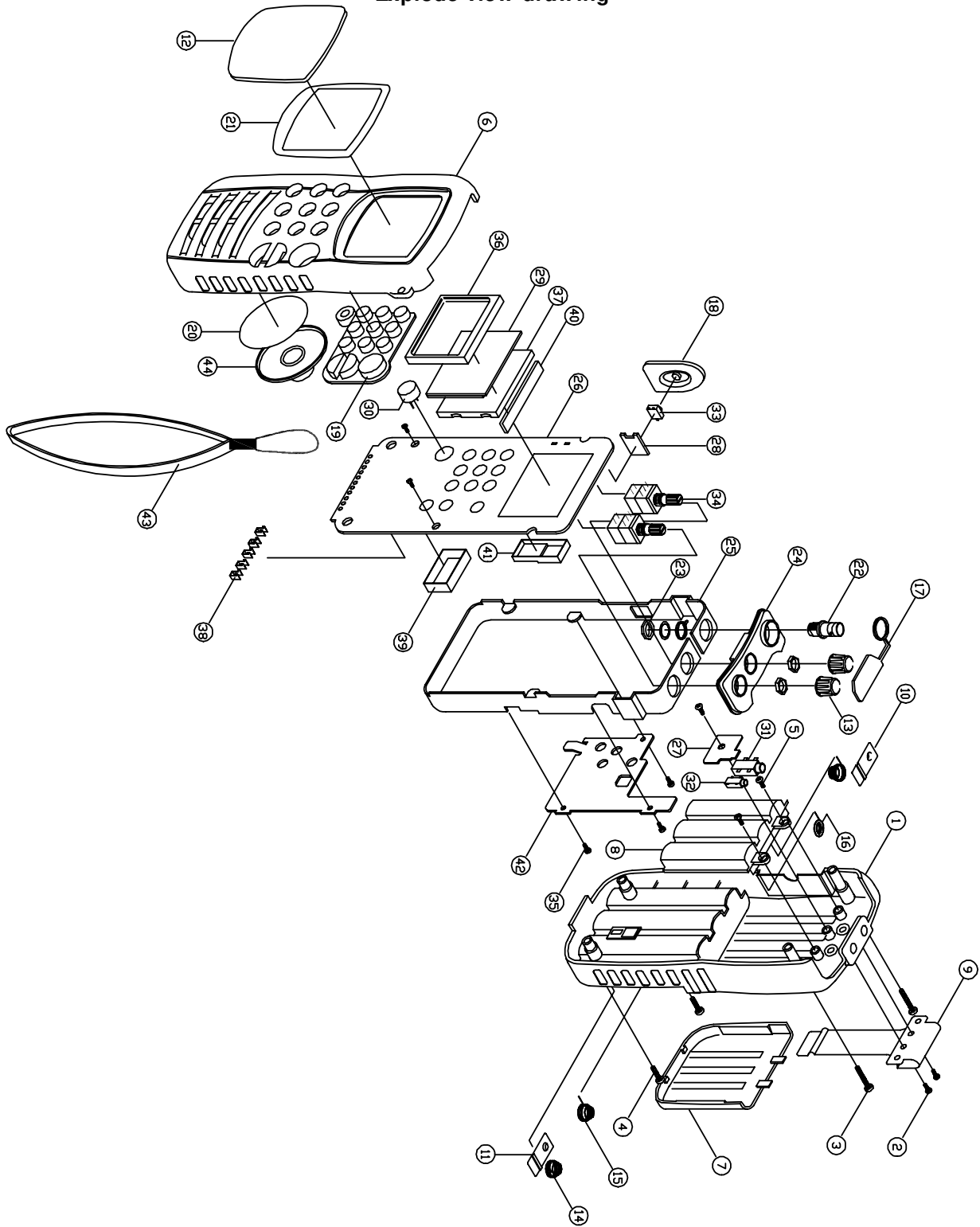

**Model No: 3420****Model No:****Drawing No:****Customer :****H 520 PLUS****Rev. Date:****Explode view part list**

No.	New Part No.	PART-NO.	NAME & DESCRIPTION	NAME & DESCRIPTION	Q'TY	REFERENCE-NO
1	501-500024AA	518185A	BOTTOM COVER ASSY		1	
2	838-602604BL	611110	SCREW	(M)2.6X4 BLK(BH)	2	BELT CLIP ASSY
3	839-302618BL	621485	SCREW	T2.6X18 BLK (PH)	2	SET ASSY up
4		621486	SCREW	T2.6X13 BLK (PH)	2	SET ASSY dn
5	839-302607BL	621487	SCREW	T2.6X7 BLK (PH)	3	HOLDER ASSY
6	834-501282AA	71A285	UPPER COVER	ABS,BLK	1	
7	834-501285AA	71A321	BATTERY COVER	ABS,BLK	1	
8	834-501277AA	733103	HOLDER BATTERY	ABS, BLK	1	
9	832-501285AA	752737	BELT CLIP	SUS304 0.6t BLK SPRAY	1	
10	832-501293AA	752904	TERMINAL (-,+)	SUS 304 0.3t	1	
11	832-501295AA	752905	TERMINAL (+,-)	SUS 304 0.3t	1	
12	835-501280AA	814558	WINDOW LCD	PC, clear	1	
13	834-501279AA	826629	KNOB	ABS, BLK	2	
14	832-501287AA	881617	SPRING(BATT)	SWP Ø0.5	2	
15	832-501288AA	881643	SPRING (-)	SWP Ø0.6 Ni-PLATING	1	
16	832-501289AA	881645	SPRING (+)	SWP Ø0.6 Ni-PLATING	1	
17	833-501279AA	896329	DUST CAP	NBR, BLK	1	
18	833-501278AA	896462	PTT PAD	SILICONE RUBBER, BLK	1	
19	833-501274AA	896485	KEYPAD	SILICONE RUBBER	1	
20	833-501216AA	906706	FELT	&32.5XT=0.3	1	
21	833-501280AA		TAPE WINDOW	3M T0.16	1	
22	925-990002ZA	4210368A	CONNECTOR PLUG	UG-1094/U(W)	1	CON4
23	837-501055AA	651169	NUT	BSBM(MB20)	2	VOL ASSY
24	834-501276AA	702485	TOP PANEL	ABS, BLK	1	
25	832-501297AA	753326	CHASSIS	EGI 0.8t	1	
26	932-502102AA	411416B	PCB MAIN	50X123.8X1.2T	1	
27	932-502102BA	411286B	PCB JACK	19.6X24.0X1.2T	1	
28	932-502102CA	411295B	PCB PTT	12.0X14.5X1.2T	1	
29	934-590100AA		LCD DISPLAY	912-841A-0100	1	LCD1
30	927-130007AA	4202741Y	MIC CONDENSER	F9745AP362-34	1	MIC1
31	925-730003AA	4208062U	JACK STEREO	EJS-4-4035S	1	JACK1
32	925-730004AA	4208073V	JACK STEREO	EJS-4-4125S	1	JACK2
33	924-160010AB	4360300	SW TACT	SKHUPFE010	1	SW4
34	924-430901AA	4504364Y	VOLUME	RS0915N-15KQA1-15A10K	2	VR601.102
35	838-600204ZN	612081	SCREW	(+)M2X4 ZN-PLAT (BH)	5	PCB+CHASSIS: 2, HEAT SINK+CHASSIS: 3
36	832-501293AA	724012	BRACKET LCD	SPT 0.3t	1	
37	834-501278AA	733057	REFLECTOR	PC, clear	1	
38	832-501296AA	753315	TERMINAL	SPT 0.3t	5	
39	832-501183AA	772428	SHIELD CAN (VCO)	NSP T0.2	1	VCO
40	833-501282AA	896389	ZEBRA	silicone rubber 38.8*1.8	1	
41	832-501283AA		SHIELD PLATE	SPT T0.3	1	TX SHIELD
42	832-501284AA		HEAT SINK	AL PTE T1.5	1	
43	836-150001AA	732750B	HAND STRAP	NYLON BLK	1	
44	927-140004ZA	4201206Z	SPEAKER	K36852F2 8 OHM	1	SP1

Created by:**Approved by:****Rev.No:****For Stage:****Release Date:****Page: 57 Of 57**